

Energy Management Controller MS-EMS

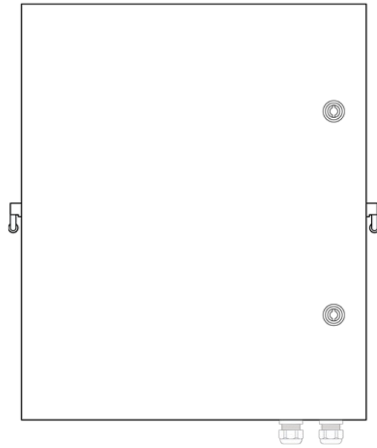

Preface

This manual provides information on safety, installation, electrical connection, operation, maintenance, and other relevant aspects of the product.

In this manual, the terms “equipment”, “device”, and “product” refer to the product or its components; the terms “manufacturer”, “producer”, and “the Company” refer to NINGBO DEYE ESS TECHNOLOGY CO., LTD. (hereinafter referred to as the “Company”) or its authorized agents.

The illustrations in this manual are for reference only and may differ from the actual product. The Company reserves the right to modify the content without prior notice. For the latest version, please visit our official website or contact our after-sales service.

The Company assumes no liability for any losses arising outside the scope of the warranty policy.

Copyright



Copyright © 2026 NINGBO DEYE ESS TECHNOLOGY CO., LTD. All rights reserved.

No part of this manual may be reproduced, distributed, modified, or translated in any form or by any means without the prior written permission of the Company.

Trademarks

All DEYE trademarks used in this manual in any form are the property of the Company. Any other trademarks, registered trademarks, logos or service marks mentioned in this manual are the property of their respective owners.

Convention

Symbols	Description
 DANGER	Indicates an imminently hazardous situation which, if not avoided, will result in death or serious injury.
 WARNING	Indicates a potentially hazardous situation which, if not avoided, could result in death or serious injury.
 CAUTION	Indicates a potentially hazardous situation which, if not avoided, could result in minor or moderate injury.
NOTE	Indicates supplementary explanation, clarification, or emphasis on a particular content for better understanding.



NINGBO DEYE ESS TECHNOLOGY CO., LTD. hereby confirms that the products described in this document comply with the fundamental requirements and other relevant provisions of the applicable EU directives.

Technical Assistance

Add.: 6F No.8 building, No.568 Rixian South Road, Cixi Binhai Economic Development Zone, Zhejiang, P.R. China

Tel.: 0086 0574-63702591

E-mail: service-ess@deye.com.cn









Contents

1 Safety	1
1.1 Symbols	1
1.2 Safety Precautions.....	1
2 Product Description.....	4
2.1 Product Overview.....	4
2.2 Product Appearance.....	5
2.3 Internal Structure.....	6
3 Installation.....	7
3.1 Pre-Installation Preparation.....	7
3.1.1 Site Requirements.....	7
3.1.2 Tool Requirements.....	10
3.2 Transportation Methods.....	12
3.2.1 Manual Handling.....	12
3.2.2 Forklift.....	13
3.3 Unpacking.....	14
3.4 MS-EMS Installation.....	15
3.4.1 Wall Mounting.....	15
3.4.2 Cabinet Mounting.....	16
4 Electrical Connection.....	18
4.1 Safety Precautions.....	18
4.2 Preparation before Connection.....	18
4.3 Cable Connection.....	19
4.3.1 DRM Dry Contact Connection (Optional).....	20
4.3.2 AC220V Auxiliary Power and DC24V Supply Power.....	21
4.3.3 Signal Output.....	22
4.3.4 Ring Network Communication Cable.....	23
4.3.5 Grounding.....	24
5 Maintenance.....	25
5.1 Safety Precautions.....	25
5.2 Maintenance Schedule.....	26

5.3 Post-Maintenance Requirements.....	26
5.4 Storage.....	27
6 Technical Specifications.....	28
Appendix 1 Troubleshooting.....	30
Appendix 2 Emergency Handling.....	31
Appendix 3 EU Declaration of Conformity.....	33

1 Safety

1.1 Symbols

Symbols	Description
	Do not step on the equipment
	No open flame; Fire, open ignition source and smoking prohibited.
	Recycling Symbol
	Operator's manual
	This way up
	Fragile
	Keep away from rain
	Do not roll
	Do not stack

1.2 Safety Precautions

Personal safety

DANGER

- Operators must carefully read and comply with all safety information in this manual and relevant document. Improper operation may cause casualties.
- Keep the product out of reach of children and animals.
- No one except DEYE staff or authorized personnel is allowed to open, repair or disassemble the product.
- Only qualified professionals or trained personnel are permitted to install and operate the equipment.
- It is prohibited to handle open flames and ignition sources near the product.

WARNING

- Personnel performing wiring operations on the equipment shall possess knowledge of electronics, electrical wiring and mechanical expertise, and be familiar with the

electrical and mechanical schematics of this equipment.

- Service of the product must be performed by qualified personnel only. Unauthorized intervention voids all warranties and liabilities.



CAUTION

- Personnel operating this equipment shall understand and comply with the requirements of this manual and other applicable documents.
- Components may become extremely hot in case of malfunction; touching is prohibited to prevent scalding.
- Personnel planning to install and operate the equipment must master all necessary safety precautions and local relevant standards.
- This manual does not cover all conceivable scenarios; applicable standards and relevant occupational health and safety regulations shall take precedence during operation.

NOTE

- Qualified professionals: Personnel who are familiar with the working principles and structure of the equipment, have received training or have experience in equipment operation, and are clear about the sources and degrees of various potential hazards in equipment installation.
- Trained personnel: Personnel who have received technical and safety training, have the required experience, are aware of potential hazards to themselves during certain operations, and can take protective measures to minimize hazards to themselves and others.

Electrical Safety



DANGER

- Dangerous lethal high voltage is present inside the unit. Contact with live terminals and internal charged parts will result in fatal electric shock.



WARNING

- Before any installation, maintenance or inspection work, cut off and isolate all external and internal power sources. Confirm the unit is fully de-energized before operation.
- The product must be well grounded with a grounding resistance of less than 1Ω.
- Use insulated tools and gloves during operation, and remove metal accessories such as watches and rings.
- Prevent terminals from contacting exposed wires or metal objects.
- Adjacent live parts shall be covered or shielded.



CAUTION

- Ensure correct wiring. Distinguish positive and negative poles strictly to prevent short circuits with external devices.

Mechanical Safety



DANGER

- Installation or operation of the product in explosive or high-humidity areas is strictly prohibited.

 **WARNING**

- Do not insert foreign objects into any part of the cabinet.
- Place necessary warning signs or barriers near the product to prevent accidents caused by misuse or unrelated persons.

NOTE

- Inspect the product immediately after unpacking. Contact your vendor if damaged or parts are missing.
- Contact the supplier within 24 hours if any abnormality occurs to the product.

Maintenance Safety

 **DANGER**

- Disassembling, modifying, or opening the product is strictly prohibited.

 **WARNING**

- Power off the cabinet completely before moving or performing any maintenance.
- All terminals and circuit connectors must be disconnected during maintenance.
- Maintenance shall follow the principles: power off, prevent restart, verify no voltage, grounding and short-circuit protection, shield adjacent live parts.
- Residual safety risks may arise from failure to observe warnings, improper installation, or construction by untrained personnel.

NOTE

- Do not paint any internal or external components of the product.
- Do not clean the products with cleaning solvents.

Environmental Safety

 **DANGER**

- Do not expose the product to fire, heaters, high-temperature sources, or open flames.
- In case of fire, use only dry chemical fire extinguishers. Liquid extinguishers are forbidden.
- Do not dispose of the product as household waste. Improper handling may cause explosion, fire or severe chemical injury.

 **WARNING**

- Do not expose the product to flammable substances, harsh chemicals, or their vapors.
- Do not submerge the product in water or expose it to moisture (The product's protection rating is valid exclusively when the product is in its complete, fully assembled configuration).

2 Product Description

2.1 Product Overview

The MS-EMS is an energy management controller specifically configured for Energy Storage Systems (ESS), hereinafter referred to as the Controller. It serves as the core control unit for energy storage power plants or commercial and industrial energy storage projects, responsible for overall operation monitoring, energy dispatch, safety protection, and data analysis of the energy storage system.

This manual only describes the hardware part of the MS-EMS system. For the corresponding software user manual, please scan the QR code below to access it



Product features:

1. AI Intelligence:

- Large capacity energy aggregation
- Real-time electricity price revenue calculation
- One-click generation of statistical charts
- Maximum profit charging and discharging strategy

2. Efficient Operation and Maintenance:

- Local / cloud operation and maintenance to ensure stable device operation
- Combination of multiple operation and maintenance methods for WEB / APP

3. Safety and Reliability:

- Real-time alarm for equipment malfunction
- SOC balance management

2.2 Product Appearance

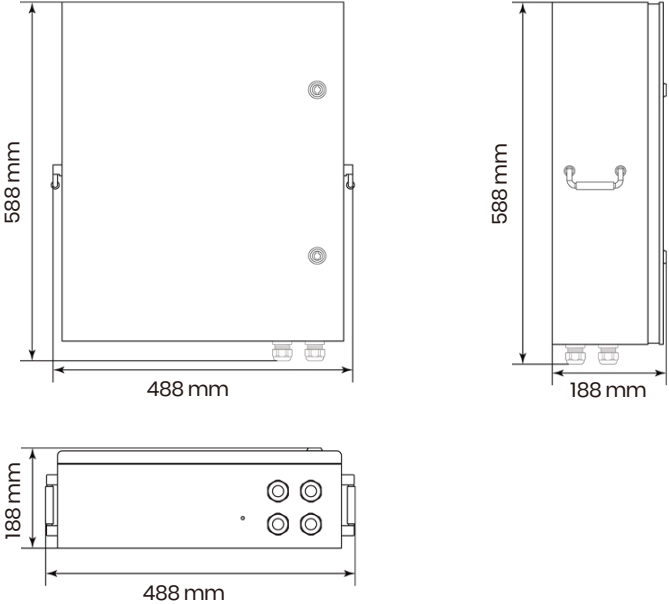

2.3 Internal Structure

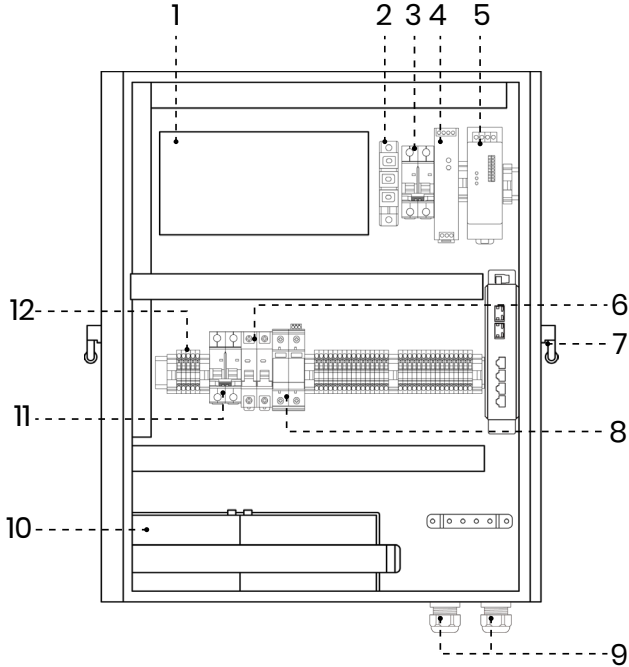

No.	Item	No.	Item
1	Energy management module (EM-1000)	7	Handle
2	Diode	8	Surge protection device (SPD1)
3	Lead-acid battery circuit breaker QF2	9	Cable Outlet
4	AC/DC power module (PS1)	10	UPS module backup lead-acid battery
5	DC24V backup power module (UPS)	11	AC auxiliary power supply circuit breaker QF1
6	Surge protector device circuit breaker (SCB1)	12	Power supply interface

3 Installation

3.1 Pre-Installation Preparation

3.1.1 Site Requirements



DANGER

- Do not install the equipment in low-lying areas where it may become submerged. The installation level must be at least 300 mm above the highest historical water level in the area. Do not install in any position that could be submerged in water.



WARNING

- Install the equipment in an outdoor area far from liquids. Do not install it under areas prone to condensation (e.g., under water pipes, air exhaust vents) or water leakage (e.g., air conditioner vents, ventilation vents, equipment room feeder windows). Liquid ingress may cause equipment faults, short circuits, fires, or electric shock.
- To prevent high-temperature damage or fire, ensure that the equipment's ventilation vents and heat dissipation systems are not obstructed or covered by other objects during operation. Poor heat dissipation can lead to equipment overheating, fire, or explosion.
- To protect the equipment from wildfires caused by high summer temperatures, ensure there are no vegetation or flammable plants within 3 meters of the equipment. Wildfires can spread to the equipment, causing explosions or fires.
- For safety purposes, the distance between the equipment and residential buildings must be more than 12m, and the distance between the equipment and densely populated buildings (such as schools, hospitals) must be more than 30.5m. If this safety distance cannot be met, a firewall must be built between the equipment and the building to prevent fire or explosion hazards from affecting people.
- Outdoor controller and systems must be at least 10 feet away from boundaries, public roads, buildings, flammable materials, hazardous materials, high piles, and other non-grid-related hazards to reduce the risk of fire, explosion, or collision-induced accidents.
- Do not install the equipment in places without proper fire-fighting facilities or where firefighters cannot easily access. In the event of a fire, lack of fire protection or accessibility will lead to the rapid spread of fire, resulting in serious injury or death.
- Do not install the equipment in an easily accessible location. The enclosure and heat sink of the controller reach high temperatures during operation, which may cause severe burns.
- Do not install the controller on moving objects (such as ships, trains, or cars). Vibration and instability during movement may damage the equipment, leading to leaks, fires, or explosions.
- Do not install the equipment in environments with magnetic dust, volatile or corrosive gases, infrared or other radiation, organic solvents, conductive metals, or salty air. These environments can corrode or damage the equipment, leading to short circuits, fires, or explosions.
- Do not install the equipment near areas that may produce interfering or harmful

gases (such as garbage dumps or chimney outlets). These gases may corrode the equipment or create an explosive atmosphere.

- Do not install the equipment in areas with strong vibration, noise, or electromagnetic interference. These factors can damage the equipment’s internal components, leading to malfunctions, fires, or explosions.
- During the installation, commissioning, and operation of the controller and system, ensure that each unit is equipped with no less than 2 fire extinguishers nearby. Insufficient fire-fighting equipment may result in uncontrollable fires, leading to death or serious injury.

 **CAUTION**

- Do not install the equipment in areas conducive to the growth of microorganisms (such as fungi or mildew). Microbial growth may damage the equipment’s surface or internal components, leading to malfunctions and potential minor injuries during maintenance.
- Do not install the controller in salt-damaged or polluted areas. Corrosion caused by these environments may damage the equipment, leading to malfunctions and minor injuries during handling or maintenance.

The controller must be installed in locations that meet the following criteria:

Condition	Required Distance	Examples
Distance from coast	More than 2000 m	/
Distance from pollution sources	Heavy pollution sources: ≥ 1500 m	Smelters, coal mines, thermal power plants
	Moderate pollution sources: ≥ 1000 m	Chemical, rubber, electroplating
	Mild pollution sources: ≥ 500 m	Food, leather, heating boilers, slaughter houses, centralized garbage dumps, sewage treatment stations

NOTE

- The safe distance between the equipment and production buildings shall comply with local fire codes or standards.
- Install the equipment in a clean, dry, and well-ventilated area with appropriate temperature, humidity, and altitude. For detailed parameters, refer to **Chapter 6 Technical Specifications**.
- Reserve sufficient space for expansion according to the whole-life cycle needs of the controller.

Recommended clearance

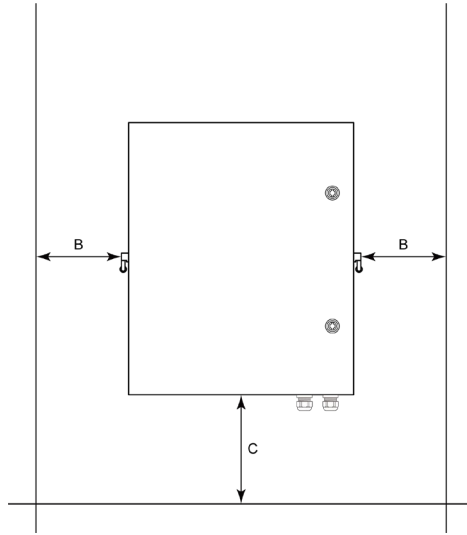

Front View

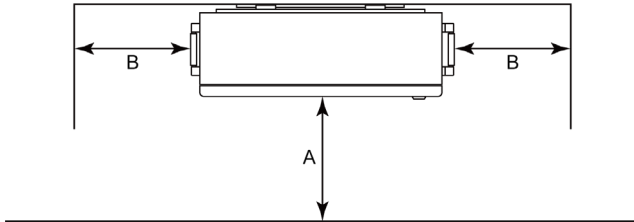













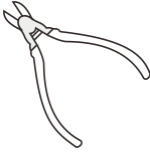

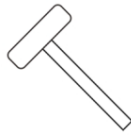
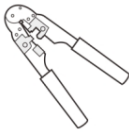
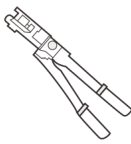



Top View

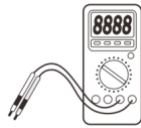





Item	Distance (mm)
A	≥200
B	≥200
C	≥300

3.1.2 Tool Requirements

Recommended installation tools are listed below and the pictures are for reference only.

Tools			
			
Hammer drill	Phillips insulated torque screwdriver	Flat-head insulated torque screwdriver	Insulated torque socket wrench
			
Diagonal pliers	Wire stripper	Cable cutter	Rubber mallet
			
Manual crimping pliers	Hydraulic pliers	Needle-nose pliers	Marker
			
Utility knife	Steel measuring tape	Level	Multimeter DC voltage measurement
			

Heat shrink tubing	Heat gun	Cable tie	Insulated ladder
			
Powered industrial forklift	Crane		

Personal Protective Equipment			
			
Insulated gloves	Protective gloves	Goggles	Dust mask
			
Insulated shoes	Safety helmet	Protective suit	

3.2 Transportation Methods

Select the appropriate transport method according to the table below.

Weight	Method
<18 kg (40lbs)	Manual handling (1 person)
18~32 kg (40~70lbs)	Manual handling (2 persons)
32~55 kg (40~70lbs)	Manual handling (3 persons)
55~68 kg (121~150lbs)	Manual handling (4 persons)
> 68 kg (150lbs)	Forklift

3.2.1 Manual Handling

Before handling:

- Confirm that all personnel are in good physical condition before handling, wear anti-slip gloves, anti-slip shoes and necessary waist protection equipment to avoid injuries.
- Clean the handling path in advance to ensure a safe ground; slow down on slopes with special personnel assistance, and reserve sufficient operating space in narrow areas.
- When assigning carriers, the number of personnel shall be reasonably determined in accordance with the “Recommended Limits for Single Lifts by Healthy Adult Workers” specified in ISO 11228-1:2003 (25kg for males, 15kg for females), combined with the requirements for handling stability, load distribution and safety redundancy.

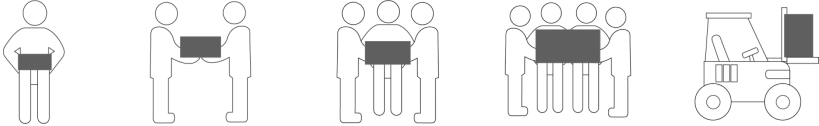

When handling:

- When manually lifting an object, move close to it, squat down, and lift smoothly and steadily using leg strength instead of back strength. Do not jerk or twist your body during lifting.
- Move or lift the equipment only by its designated handles or lower edges. Do not hold the handles of modules installed inside the equipment.
- Do not rapidly lift heavy objects above waist height. Place the object on a waist-height workbench or other suitable surface, reposition your hands, and then continue lifting.
- Move heavy objects smoothly, with balanced force and at a slow, constant speed. Lower the object gently and steadily to avoid collisions, drops, scratches, or damage to components and cables.
- When moving heavy objects, pay attention to workbenches, slopes, stairs, and slippery areas. When moving through a doorway, ensure the opening is sufficiently wide to prevent impact or injury.
- When carrying heavy objects, turn by moving your feet instead of twisting your waist. When lifting and carrying, keep your feet pointing toward the intended direction of movement.

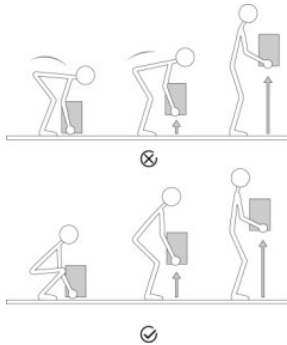

After handling:

- After handling, confirm that the load is placed stably to avoid injury caused by tipping.

3.2.2 Forklift

 **DANGER**

- During forklift operation, unrelated personnel must keep at least a 2m safe distance; standing or riding on the forklift or cargo is strictly prohibited.
- Overloading and lifting loads too high are strictly prohibited to avoid forklift instability and rollover risks.
- Only certified professional forklift operators may perform operations; unauthorized operation by non-professionals is forbidden. Strictly follow all clauses; violators bear full responsibility for equipment damage and personal accidents.

Fork Positioning & Loading:

Insert forks strictly into the designated "Forklift Fork Insertion" mark (↓) on the packaging, following the supporting diagram for details. When lifting heavy or unbalanced loads, align with the equipment's center of gravity mark (⊕) to ensure balanced stress.

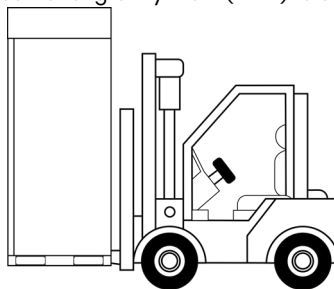

Driving & Steering:

- Driving speed shall be strictly controlled below 3 miles per hour (3mph). Sharp turns are strictly prohibited to avoid cargo shaking and imbalance.
- Before reversing, the forklift operator must carefully check the rear area and confirm safety before reversing. When reversing in confined spaces, a special commander must be arranged to guide the operator throughout the process.
- Operating forklifts on slopes with a gradient $\geq 5^\circ$ is strictly prohibited. Slow down and operate carefully when lifting loads on uneven roads.
- Tilting or inverting the controller is strictly prohibited during the whole transfer process. If tilting or inversion is necessary under special circumstances, restore the controller to upright position as soon as possible, and leave it standing for 2 hours before power-on.

3.3 Unpacking



CAUTION



- If possible, do not remove the transport packaging until the equipment arrives at the installation site.
- After preparing the equipment for installation, unpack it carefully to avoid scratching the equipment.
- Keep the equipment stable during unpacking.

NOTE

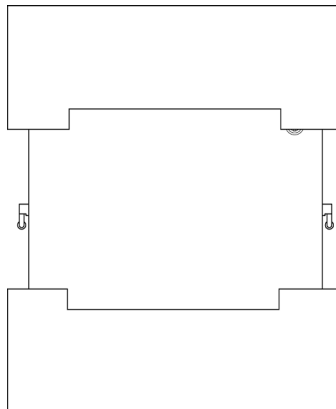
- After unpacking the equipment, check that the deliverable contents are intact and complete, and free from any damage. If any items listed in the Packing List is missing or damaged, contact your dealer or our after-sales service team.
- All components must be thoroughly cleaned before assembly to remove burrs, flash edges, oxide layers, rust, sand particles, dust and stains, ensuring a clean and impurity-free surface.
- EPE foam is widely adopted for product packaging, featuring shock resistance and easy disassembly. The equipment can be unpacked using a cutter or utility knife.

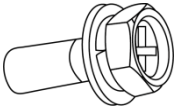
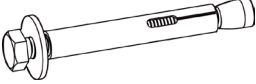

Packing List

		
M6x10 Cross recessed hexagon bolt with indentation x8 pcs	M6x100 Expansion bolt x4 pcs	Key x2 pcs

3.4 MS-EMS Installation

WARNING

- Assembly must be carried out in accordance with the design, technological requirements, regulations and relevant standards.
- The parts shall not be bumped, scratched or rusted during assembly.
- Wear appropriate personal protective equipment at all times during any assembly operation on site.

NOTE

- If you have purchased the AC collection cabinet **MS-TS500-2-A** from our company, it is recommended to install the MS-EMS on this cabinet.

3.4.1 Wall Mounting

1. Select an appropriate installation location and mark hole positions on the wall.
2. Drill the holes with a depth of 100-110 mm using an electric drill.
3. Secure the mounting plate onto the wall with 4 M6x100 expansion bolts.

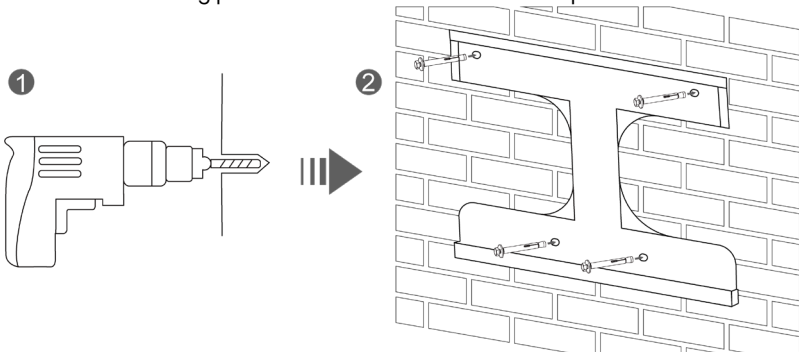

6. 4. Secure wall-mounting bracket on the rear of MS-EMS with 8 M6×10 expansion bolts.

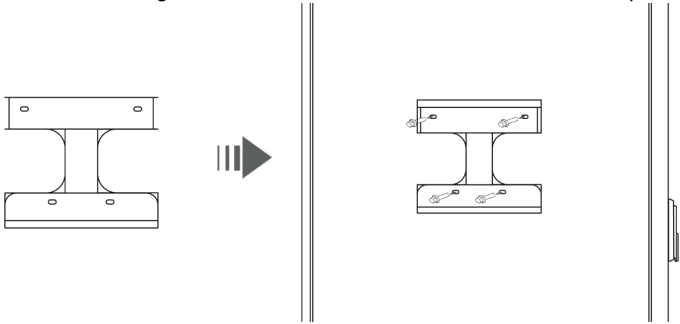

7. 5. Attach the MS-EMS on the mounting plate.

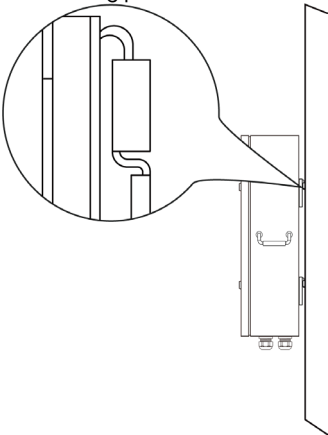

3.4.2 Cabinet Mounting

1. Secure the mounting plate onto the AC collection cabinet **MS-TS500-2-A** with 4 M6×100 expansion bolts.

NOTE

- The mounting holes are reserved on the AC collection cabinet **MS-TS500-2-A**. For specific steps, please refer to the user manual of that product **MS-TS500-2-A**.

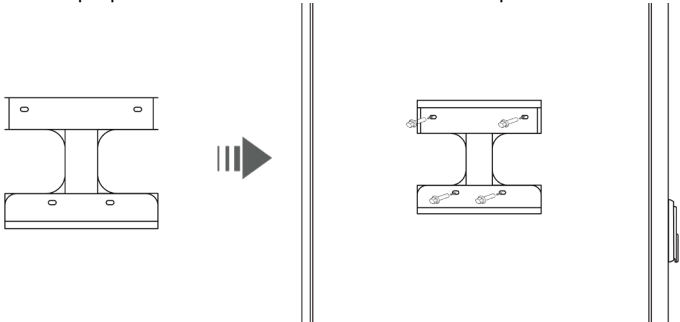

8. 2. Secure wall-mounting bracket on the rear of MS-EMS with 8 M6×10 expansion bolts.

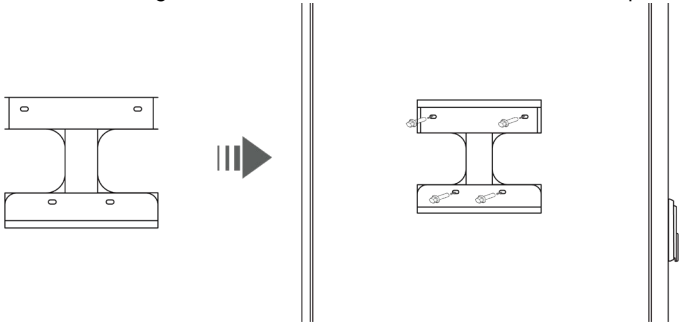

9. 3. Attach the MS-EMS on the mounting plate.

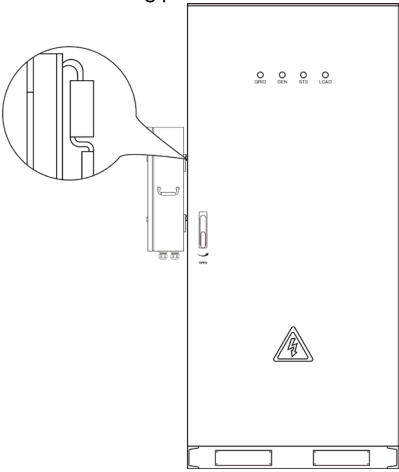

4 Electrical Connection

4.1 Safety Precautions



DANGER

- All electrical connections must be performed with the equipment completely de-energized.
- Do not smoke or use open flames near the equipment. Wear personal protective equipment (PPE) and use dedicated insulated tools to prevent electric shock and short circuits.
- Do not place installation tools, metal parts, or other debris on the equipment during cable connection. After completing the work, clean all objects from the work area.



WARNING

- Only qualified electrical professionals can perform the electrical connection.
- The product can only be used in situations equipped with overvoltage protection devices. Do not contact live parts directly without protection.
- Do not perform electrical connections during sandstorms or when the relative humidity of the surrounding environment is greater than 95%.
- Before cable connection, ensure that there is no voltage on the AC side and DC side.
- Only allow connection of “+” to “+” and “-” to “-”.
- Before connecting cables, check that the polarity of all input cables is correct. Do not pull wires and cables forcibly during electrical installation; otherwise, the insulation performance may be affected. Ensure all cables have sufficient bending space and take necessary auxiliary measures to reduce cable stress.
- Keep clear of the equipment while preparing cables to prevent cable scraps from entering the unit. Debris inside the equipment may cause sparks, leading to personal injury and equipment damage.
- Follow the installation diagram and observe terminal polarity when connecting cables. Incorrect installation may cause the product to malfunction.

NOTE

- After cable connection, carefully verify that all connections are correct and secure.

4.2 Preparation before Connection

During electrical connection, it may be necessary to crimp OT/DT terminals to meet wiring requirements. Follow the steps below to crimp the OT/DT terminals.

1. Strip the cable insulation to expose the core wire. Avoid scratching the core wire when stripping a cable.
2. Slide a piece of heat shrink tubing over the cable, and then insert the tripped core wire into the OT/DT terminal.
3. Use a crimping pliers to perform the crimping according to the cable specifications, ensuring the connection is secure and reliable.
4. Slide the pre-installed heat shrink tubing over the crimped connection area. Use a heat gun to shrink the tubing evenly, completely covering the crimped section.

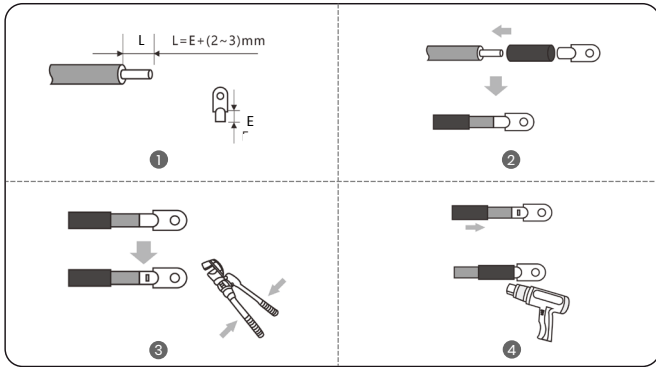

4.3 Cable Connection

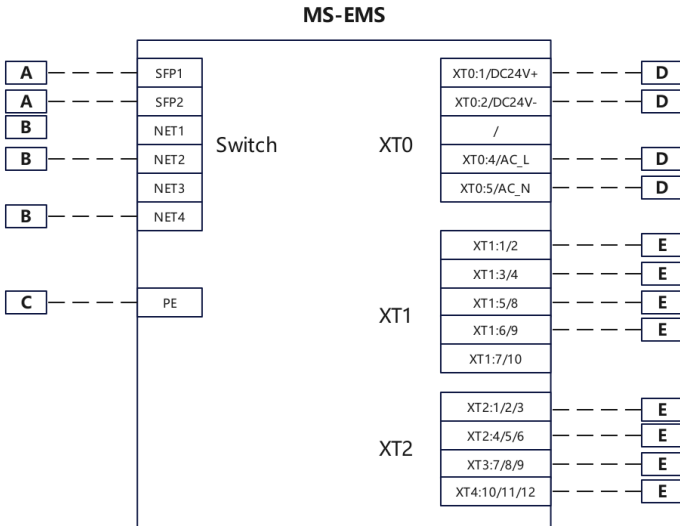

Cable	Requirements
A	1310 nm/1550 nm
B	CAT.5E
C	12 AWG
D	16 AWG
E	2*0.5mm ² , twisted pair shielded wire, twist pitch 25±5mm

The MS-EMS energy management system is recommended for use with the AC collection cabinet **MS-TS500-2-A**. If the cabinet is not purchased, the corresponding electrical connection is optional and can be skipped.

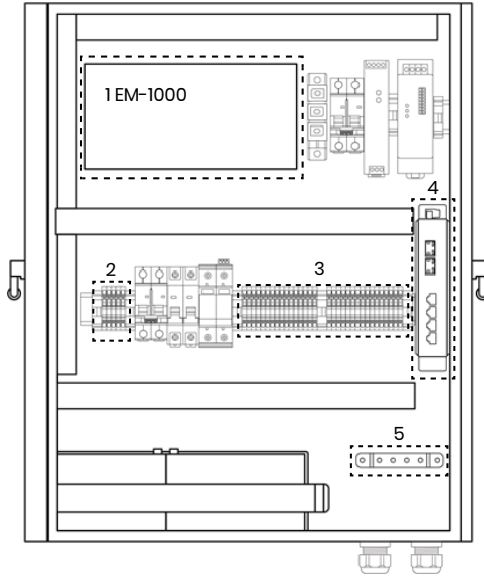

4.3.1 DRM Dry Contact Connection (Optional)

The MS-EMS system supports demand response management by providing dry contact signal connections to the corresponding terminals on the EM-1000 module.

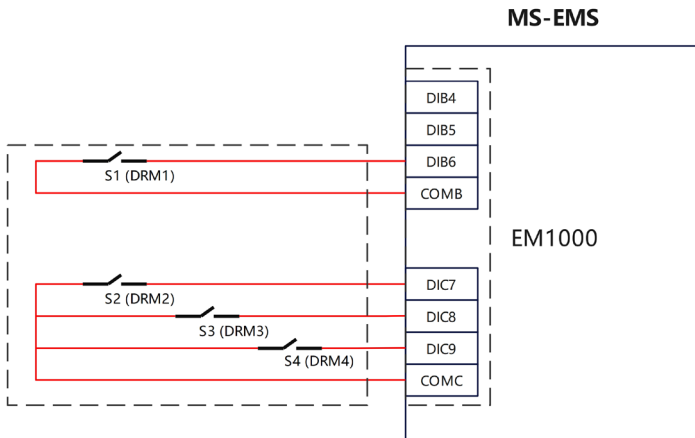

Dry Contact Circuit 1:

1. Take the 2 terminals of S1 (DRM1) dry contact output from your device.
2. Connect one terminal to **DIB6** on the EM-1000, and the other terminal to **COMB** on the EM-1000.

Dry Contact Circuit 2:

1. Take the 2 terminals of S2 (DRM2), S3 (DRM3), and S4 (DRM4) dry contact outputs from your device.
2. Connect one terminal of each dry contact output to ports **DIC7**, **DIC8**, and **DIC9** on the EM-1000 respectively.
3. Connect the remaining terminals of S2 (DRM2), S3 (DRM3), and S4 (DRM4) in parallel to **COMC** on the EM-1000.

The table below lists the grid feed-in power limit corresponding to each of the aforementioned dry contact signals:

Item	Status	Description
S1 (DRM1)	Closed	Limits the grid feed-in power $\leq 0\% \times$ AC rated total power.
S2 (DRM2)	Closed	Limits the grid feed-in power $\leq 30\% \times$ AC rated total power.
S3 (DRM3)	Closed	Limits the grid feed-in power $\leq 60\% \times$ AC rated total power.
S4 (DRM4)	Closed	Limits the grid feed-in power $\leq 100\% \times$ AC rated total power.

4.3.2 AC220V Auxiliary Power and DC24V Supply Power

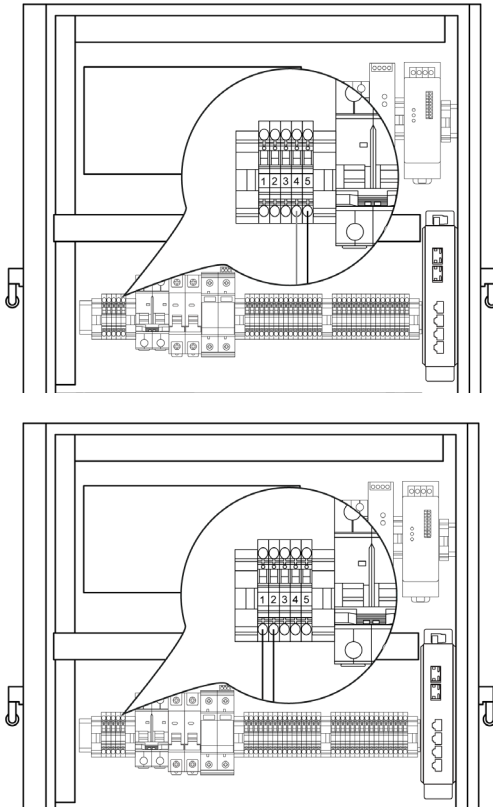

Cable	Port
Auxiliary Power	XT0:4 (Optional)
	XT0:5 (Optional)
Power Cable	XT0:1
	XT0:2

4.3.3 Signal Output

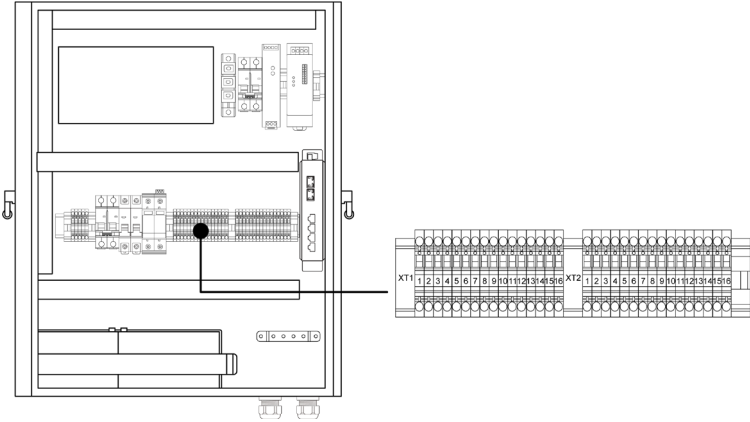

Cable	Port
Signal Output	XT1:1
	XT1:2
	XT1:3
	XT1:4
	XT2:1 (Optional)
	XT2:2 (Optional)
	XT2:4
	XT2:5
	XT2:7
	XT2:8
	XT2:10
XT2:11	

4.3.4 Ring Network Communication Cable

Option 1: When the length of the communication cable is **no more than** 100 meters.

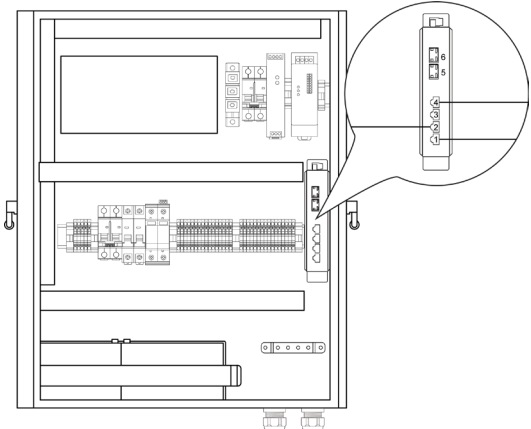

Cable	Port
Communication Cable	SW:1
	SW:2
	SW:4 (Optional)

Option 2: When the length of the communication cable is **longer than** 100 meters.

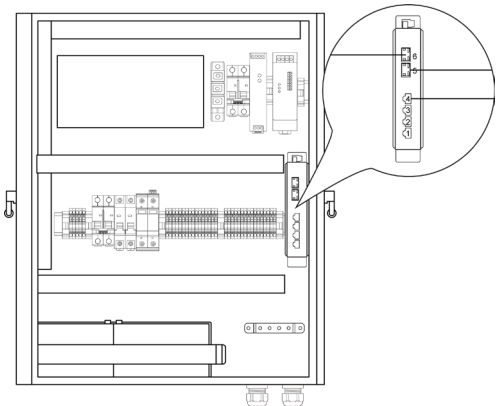

Cable	Port
Communication Cable	SW:4 (Optional)
	SW:5
	SW:6

4.3.5 Grounding

⚠ DANGER

- Ensure that the PE cable is securely connected. Otherwise, electric shocks may occur.
- After completing the grounding connection, the grounding resistance must be measured. The specific grounding resistance value should comply with the relevant national/local standards and regulations.
- The PE point at the AC output port is used only as a PE equipotential bonding point and cannot substitute for the PE point on the enclosure.

NOTE

- It is recommended that silicone grease or paint be applied around the ground terminal after the PE cable is connected.

Align the OT/DT terminal of the ground cable with the Protective Earth Terminal, then tighten the screw using an insulated torque socket wrench to ensure a secure connection.

Recommended torque: 25 N·m.

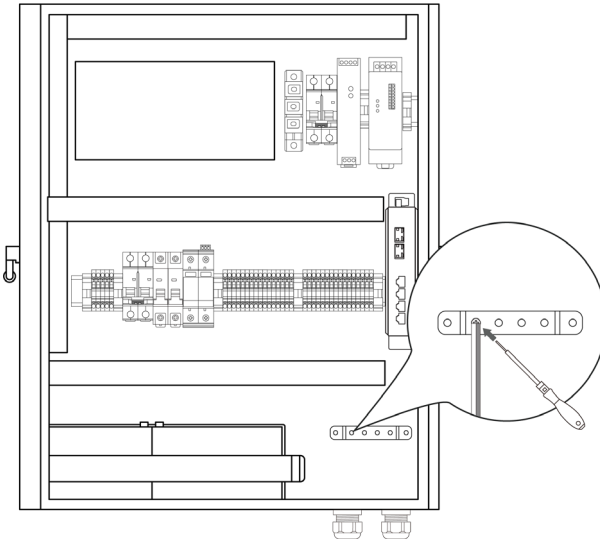

Cable	Cross Section (AWG)	Mounting Hole	Remarks
PE line	12	M4-sized threaded holes with a thread depth of 18 mm	Prepared by the user

5 Maintenance

5.1 Safety Precautions



DANGER

- Maintenance shall be performed or supervised by qualified professional personnel.
- Wear personal protective equipment (PPE) and use dedicated insulated tools to avoid electric shocks or short circuits.
- Do not smoke or have open flames in the vicinity of the equipment.
- Do not wear jewelry, watches or other metallic accessories during maintenance.
- All terminals must be disconnected for maintenance.
- It is forbidden to dismantle, dissect or open the controller; no serviceable parts are contained inside the controller.
- Electrolyte released from a damaged battery is harmful to skin and eyes and may be toxic; do not touch it.



WARNING

- Never maintain energized batteries. Disconnect mains power and batteries before moving or reconnecting the equipment, and wait 5 minutes until the equipment powers off. Verify no hazardous voltage remains with a multimeter before maintenance.
- Improper decommissioning may cause damage to equipment. Ensure the product is decommissioned in accordance with relevant provisions before maintenance.
- Keep the equipment clear of the cable preparation area. Cable scraps entering the equipment can cause sparks, resulting in personal injury or equipment damage.
- Do not clean the equipment with water or any solvent.



CAUTION

- Place a warning sign at the switch stating that the switch must not be switched on.
- Use an electroscope of the proper voltage level to verify the equipment is completely de-energized.
- Before maintenance or repair, securely connect the circuit to be serviced to the main grounding system. Remove the grounding connection upon completion.
- Insert and remove cables in accordance with regulations; violent or forced operations are prohibited.
- Clean tools and materials promptly after maintenance, and check for any metallic objects left inside or on top of the product.
- When replacing batteries, use spare parts of the same type and specification.
- Contact the customer service center for any operation and maintenance queries; unauthorized operation is prohibited.

5.2 Maintenance Schedule

NOTE

- Perform maintenance as required by site conditions.

Maintenance Item	Description	Frequency
Environment & Safety	Check that temperature and humidity inside the controller are within reasonable ranges.	3 months
	Ensure no flammable or explosive materials around the product.	6 months
	Ambient temperature and humidity within operating ranges.	6 months
Appearance & Structure	Ensure no foreign objects wrap or cover the product exterior.	1 day
	Visual inspection of the product: no obvious paint peeling or rust, no dust at vents, fasteners secured, parameter settings normal	3 months
	Check controller door and sealing strip; no foreign matter, dust or condensed water inside	12 months
	Check internal screws for no loss or rust	12 months
	Warning labels and marks legible and intact; replace if stained or damaged	12 months
Electrical & Connections	Cables: securely connected, undamaged, no water ingress, intact insulation tape at terminals, proper routing	6 months
	Reliable grounding and equipotential bonding	6 months
Battery	Proper ambient temperature/humidity, normal operating voltage and current	3 months
	No rust or foreign objects; fan operates properly	6 months

5.3 Post-Maintenance Requirements

After completing maintenance operations, follows the steps below to restore the site and archive the maintenance records:

Step	Operation
1. Cleaning & Restoration	Remove all temporary measures (e.g., grounding and warning signs) and wiring is restored to original condition. Prevent foreign objects from being left behind or personnel from inadvertently entering.

2. Recording & Archiving	Create traceable maintenance records, including the time, personnel and equipment status, and archive the records.
--------------------------	--

5.4 Storage

NOTE

- For long-term storage, keep the original packaging and check it regularly.



WARNING

- Keep the product far away from high-temperature heat sources, open flames, flammable and explosive areas, and all ignition sources, and do not expose it to direct sunlight or rain.
- During storage, ensure the product is completely disconnected from external equipment, with all operation indicators off.
- Store the product in a dry, clean, well-ventilated indoor area on flat, solid ground, away from strong infrared radiation, organic solvents, corrosive gases, and conductive metal dust.
- Handle with care. Dropping, collision, overturning, side placement, or tilting are strictly prohibited. Do not stack or roll the product improperly.
- Strictly comply with the storage requirements of the warning signs and other information on the packaging to avoid device damage.
- The storage area must be equipped with qualified fire-fighting facilities, including fire sand and special fire extinguishers.

MS-EMS Controller Storage Requirements

- **Storage Temperature:** -15°C ~ 50°C
- **Humidity:** 5% ~ 95% relative humidity, no condensing;
- **Altitude:** ≤3000 m

Long-Term Storage (> 6 months):

- Replace desiccants with the same specifications and quantity regularly.
- Check the outer packaging every 3 months, and replace damaged packaging immediately.
- Storage duration is calculated from the latest charge date marked on the packaging. If the allowable storage period is exceeded, report to the person in charge immediately.
- Maintain temperature and humidity per the storage requirements.

6 Technical Specifications

Model	MS-EMS
System	
Configuration	EMS controller, lightning protection module, switch power supply, UPS module, switch
Single Point Access Capacity	Energy storage≤3.44MWh, Photovoltaic≤1.6MWp
Function	Basic functions: peak valley arbitrage, anti-backflow, main transformer overload protection, load tracking, demand control, backup power function, phase separation control, SOC balancing, Deye Cloud monitoring. Advanced features: load forecasting, production planning, electricity price planning, optimal economic curve
Communication Interface	
Ethernet (5 channels)	10/100/1000 Mbps
Optical Port (2 channels)	1Gbps
USB (2 channels)	Host
CAN (3 channels)	Isolation, with 2 channels supporting CAN-FD
RS485 (8 channels)	Isolation
RS232 (3 channels)	2 isolated channels,1 non-isolated debugging channel (DB9 socket)
TF Card (1 channel)	Standard TF card holder
LVDS (1 channel)	The physical interface is DVI (including 1 USB for touch)
M.2 Interfaces (1 channel)	PCIe2.0 XI, Scalable SSD (standard 1TB)
DI (17 channels)	Optocoupler isolation
DO (8 channels)	Relay isolation
WLAN	802.11 b/g/n/ac, HT20/40, 2.4 GHz & 5 GHz
Power Supply	
Communication Input	220Vac
DC IN	24Vdc
UPS Backup Power	24Vdc
Consumption	Max 25W
Environmental Parameters	
Operation Temperature	-15℃~50℃
Storage Temperature	-15℃~50℃
Working Humidity	5%~95%
Max. Working Altitude (m)	≤3000m
IP Rating of Enclosure	IP54
Anti-Corrosion Grade	≥C4
Mechanical Parameters	
Dimension (W×D×H, mm)	488×188×588

Weight Appr. (kg)	≤24.5kg
Installation Location	Indoor or outdoor, wall-mounted
Box Material	Metal
Incoming Specifications	<p>AC power cord: Recommended wire diameter 1.5mm²;</p> <p>DC power cord: Recommended wire diameter of 1.5mm²;</p> <p>8-core Ethernet cable: Recommended CAT5e Ethernet cable</p> <p>RS485: Recommended 0.75mm²-1.5mm² outdoor UV protection with shielding layer twisted pair cable length<1000m (baud rate 9600)</p>

Appendix 1 Troubleshooting

In the event of any fault, please contact the service center or service engineers for help.

Appendix 2 Emergency Handling



DANGER

- In the event of natural disasters (earthquake, typhoon, flood, wildfire, etc.): Prioritize personnel safety, cut off power and stop the ESS immediately.
- Do NOT operate damaged equipment without professional inspection and qualified testing after the disaster.
- Keep away from waterlogged or fire-damaged units and contact our service engineers for professional handling.



WARNING

- When the air intake/exhaust system is operating, do NOT face the exhaust vents under any circumstance.
- Refer to the user manual/product manual for product information. Do NOT open the controller door if internal safety cannot be guaranteed.

➤ **Fire/Explosion Hazards**

- Do not open the door. Evacuate immediately to at least 50 meters away from the site and call the fire department.
- Wear respiratory protection. Disconnect the upstream power supply only when safe.
- Isolate the accident area only when safe to keep unauthorized personnel away.
- Post-incident maintenance must be performed by professionals or our after-sales engineers.

➤ **Electric Shock**

- Ensure personal safety, then disconnect the power supply immediately to avoid secondary electric shock.
- Use an insulated object to separate the victim from the power source and perform first aid such as cardiopulmonary resuscitation (CPR).
- Call the emergency medical number immediately to obtain professional medical treatment.
- Protect the accident scene for investigation and evidence preservation.
- Contact professionals to conduct a comprehensive inspection of the ESS. The system may only be put back into use after repair or replacement and passing qualified testing.

➤ **Chemical Hazards**

- In case of electrolyte leakage, evacuate personnel from the affected area and notify the relevant personnel immediately. Professionals shall conduct safe collection and proper disposal of leaked substances.
- Toxic gases may be released during battery combustion or damage; evacuate personnel to a safe area immediately. If personnel are exposed or injured, call the emergency medical number for professional treatment. Respiratory protection, protective clothing and other safety equipment must be worn during hazard handling.

➤ **Mechanical Injury**

- In the event of equipment tipping, controller dropping or component detachment, disconnect power and stop ESS operation immediately.

- In case of personnel injury, administer first aid (hemostasis, bandaging, etc.) and call the emergency medical number immediately.
- If obvious odor, damage, smoke or fire is detected, evacuate personnel immediately, call the fire department, and allow professionals to handle firefighting and subsequent treatment.
- If any abnormalities are observed, professionals shall use move the controller to an open, safe area, let it stand for 1 hour while monitoring temperature, and contact the engineers.
- Contact professionals to repair or replace damaged components. The system may only be returned to service after passing inspection and testing.

➤ **Natural Disasters**

- In the event of natural disasters including earthquake, typhoon, flood, wildfire, etc., disconnect the power supply and stop ESS operation immediately.
- If the ESS is submerged or flooded, do not touch the equipment and keep clear of the waterlogged area.
- Do not use water-soaked batteries under any circumstances. Contact a qualified battery recycling service for proper disposal and scrapping.
- Before a wildfire approaches, establish a firebreak around the ESS and prepare adequate fire-fighting equipment such as fire extinguishers, fire sand, fire hoses, etc.
- After the disaster, contact professionals to fully inspect the support structure, electrical connections, etc. The system may only be reused after repair/replacement and qualified testing.

Appendix 3 EU Declaration of Conformity



250825052
www.deyeess.com

EU Declaration of Conformity

Product:Energy Management Controller
System model: MS-EMS

Name and address of the manufacturer: NINGBO DEYE ESS TECHNOLOGY CO., LTD.
No.568, South Rixian Road, Binhai Economic Development Zone, Cixi, Ningbo, Zhejiang, P.R.China

This declaration of conformity is issued under the sole responsibility of the manufacturer. Also this product is under manufacturer's warranty.

This declaration of conformity is not valid any longer: if the product is modified, supplemented or changed in any other way, as well as in case the product is used or installed improperly.

The object of the declaration described above is in conformity with the relevant Union harmonization legislation:

The Electromagnetic Compatibility (EMC) Directive 2014/30/EU;the Radio Equipment Directive (RED) 2014/53/EU; the Low Voltage Directive(LVD) 2014/35/EU.

References to the relevant harmonized standards used or references to the other technical specifications in relation to which conformity is declared:

EN 301908-1 V15.2.1:2023	●
EN 301908-13 V13.2.1:2022	●
EN 301489-1 V2.2.3: 2019	●
EN 301489-52 V1.3.1:2024	●
EN 301489-1 V2.2.3:2019	●
EN IEC 62311:2020	●
EN IEC 61000-6-1: 2019	●
EN IEC 61000-6-3: 2021	●
EN 61010-1:2001+A1	●
EN 18031-1:2024	●

Nom et Titre / Name and Title:

KunLei Yu
Test Manager

KunLei Yu

Au nom de / On behalf of:
Date / Date (yyyy-mm-dd):
A / Place :

NINGBO DEYE ESS TECHNOLOGY CO., LTD
2025-8-25 宁波德业储能科技有限公司
Ningbo, China NINGBO DEYE ESS TECHNOLOGY CO.,LTD

EU DoC-v1

NINGBO DEYE ESS TECHNOLOGY CO., LTD

No.568, South Rixian Road, Binhai Economic Development Zone, Cixi, Ningbo, Zhejiang, P.R.China