



User Manual

Model: WS-PCS2250-2-A



Contents

1	General information	1
1.1	All Rights Reserved	1
1.2	About This Manual	2
2	Product Description	3
2.1	Product Introduction	3
2.2	Intended Use	3
2.3	Product Size	4
2.4	External Overview	5
2.5	Internal Overview	6
2.6	Components	8
2.7	Critical systems	11
3	Installation	12
3.1	Materials Required	12
3.2	Moving Heavy Objects	14
3.3	Unpacking	14
3.4	Hoisting	16
3.5	Installation	19
4	Electrical Connection	30
4.1	Preparation before Connection	30
4.2	Cable Connection	34
5	Operation Instructions	42
5.1	Powering on the Equipment	42
5.2	Powering Off The Equipment	49
6	Maintenance	50
6.1	General Maintenance	50

6.2 Maintenance Schedule	51
7 Troubleshooting	61
8 Repair Paint Damage	62
8.1 Prerequisites	62
8.2 Paint Repair Description	62
9 Emergency Handling	67
9.1 Strong Impact	67
9.2 Flood	67
9.3 Fire	67
10 Storage	69
10.1 PCS Storage	71
11 Transport	72
12 Technical Specifications	75

1 General information



Warning!

Read and follow carefully all safety warnings, instructions, illustrations and specifications provided with this product. Failure to follow instructions mentioned may result in electric shock, fire or serious injury.

Save all warnings and instructions for future reference.

1.1 All Rights Reserved

No part of this document can be reproduced in any form or by any means without the formal permission of the manufacturer .

Trademarks and Permissions

The trademarks used in this manual are owned by the manufacturer. All other trademarks or registered trademarks mentioned in this manual are owned by their respective owners.

Software Licenses

* It is prohibited to use data contained in firmware or software developed by the manufacturer, in part or in full, for commercial purposes by any means.

* It is prohibited to perform reverse engineering, cracking, or any other operations that compromise the original program design of the software developed by the manufacturer.

Disclaimer

“DANGER”, “WARNING”, “CAUTION”, “NOTICE” and “NOTE” in this manual do not represent all safety matters that should be followed, and you must also comply with relevant international, national or regional standards and industry practices. The manufacturer shall not be liable for personal injury, property loss, product damage and subsequent losses under the following circumstances:

* Damages caused by force majeure, including earthquake, flood, volcanic eruption, mudslide, lightning, fire, war, military conflict, typhoon, hurricane, and so on.

* Failure to comply with the provisions of this manual.

-
- * The installation, operation and storage environment does not meet the relevant international, national or regional standards;
 - * Incorrect use of this product.
 - * Unauthorized or unqualified personnel repair the product, disassembly the rack and perform other operations.
 - * Use of unapproved spare parts.
 - * Unauthorized modifications or technical changes to the product or software.
 - * Incorrect shipment by yourself or the third party commissioned by you.
 - * Unsatisfactory materials and tools from you own that do not meet the relevant international, national or regional standards.
 - * Damage caused by yourself or the third party's negligence, intent, gross negligence, improper operation, or other accidents not caused by Deye.

1.2 About This Manual

This manual mainly describes the product information, guidelines for installation, operation and maintenance. In this manual, "equipment" or "device" refers to relevant product, software, part, spare part or service,etc; "The manufacturer" refers to the producer, seller or service provider of the equipment.

2 Product Description

2.1 Product Introduction

The PCS (Power Conversion System) container houses eighteen (18) 125kW energy storage inverters and eighteen (18) 150kW MPPT (Maximum Power Point Tracking) chargers. In general, it is used in conjunction with a energy storage system.

2.2 Intended Use

This product is responsible for the bidirectional conversion between direct current (DC) and alternating current (AC). During charging, the PCS converts externally supplied AC power into DC to charge the batteries; during discharge, it converts the DC from the batteries into AC to supply loads or feed into the grid. The entire system is intelligently monitored and managed by the Battery Management System (BMS) to ensure safe and stable operation.

2.3 Product Size



Unit:mm

2.4 External Overview

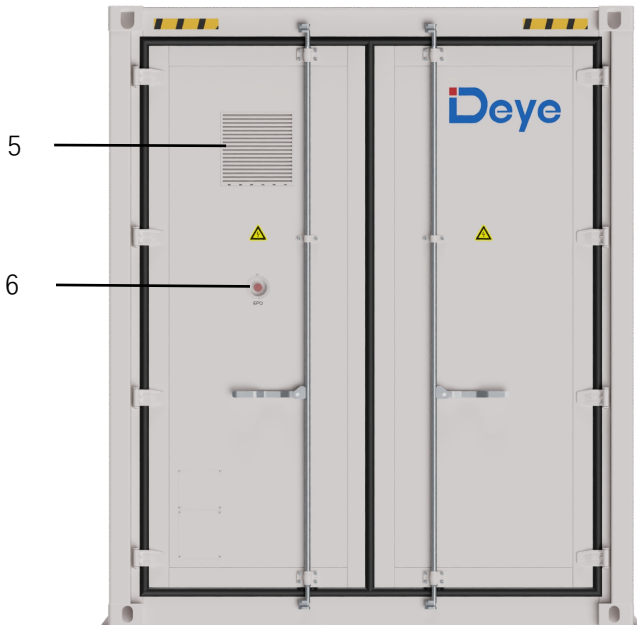

No.	Item	No.	Item
1	Air inlet of PCS cabinet ×6	4	Cabinet mounting feet×4
2	Protective earth×4	5	Air outlet of AC cabinet
3	Air inlet of AC cabinet	6	EPO (Emergency stop)

2.5 Internal Overview

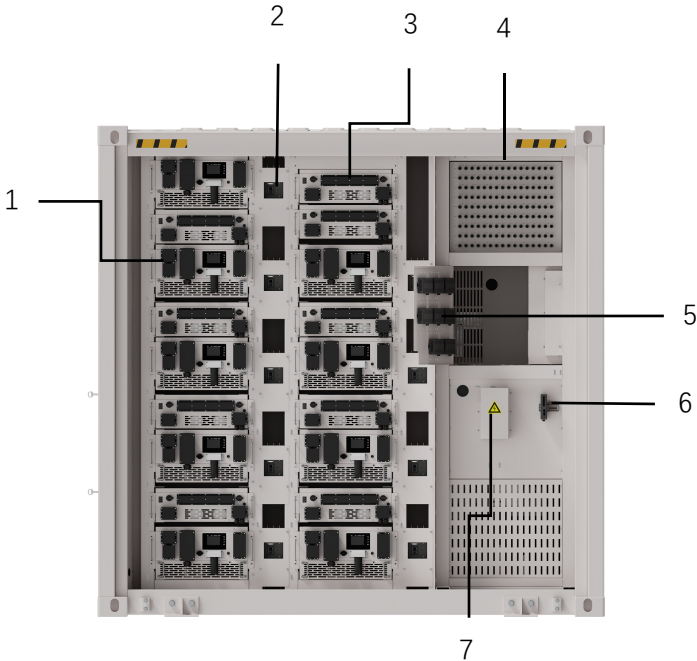

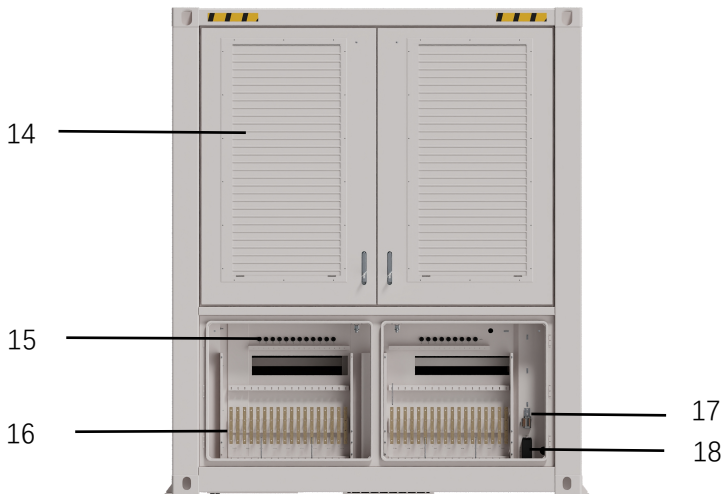
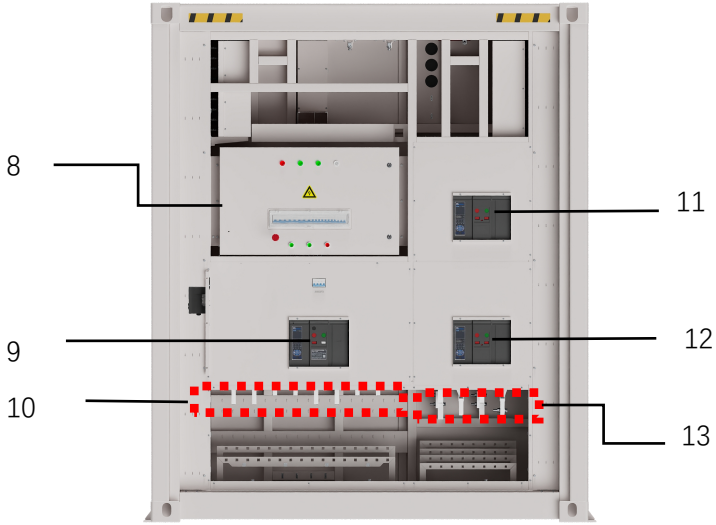

No.	Item	No.	Item
1	PCS×18	10	Grid interface
2	PCS breaker×18	11	Load breaker
3	MPPT×18	12	Generator breaker
4	PV interface	13	Load&Generator interface
5	Serial device server×8	14	Air outlet of PCS cabinet
6	Customer interface /internet interface	15	Internet interface
7	Auxiliary power interface	16	DC input &output interface
8	Control box	17	UPS input &output interface
9	Grid breaker	18	Auxiliary power input &output interface

2.6 Components

The PCS container WS-PCS2250-2 mainly houses eighteen (18) 125kW energy storage inverters and eighteen (18) 150kW MPPT chargers.



2.6.1 MPPT

Maximum Power Point Tracking (MPPT) is an intelligent electronic control system, specifically a type of power regulator or solar charge controller, designed to maximize the energy output from power generation devices like solar panels or wind turbines . Its core function is to intelligently track and maintain the operational point at which the connected photovoltaic (PV) array delivers its maximum possible power output.

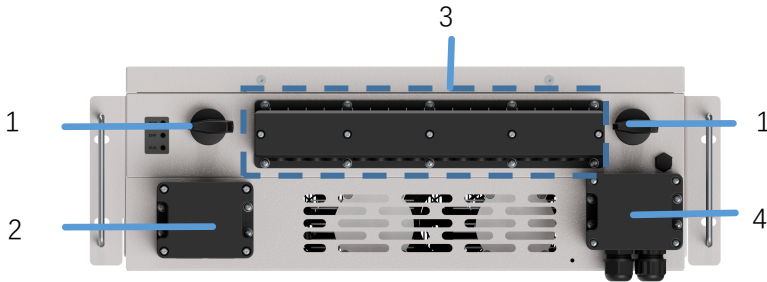

NO.	Designation	Description
1	PV switch 1	A device used to manually control the MPPT
2	Battery input	Connection position of battery input terminals
3	PV input port	Connection position of PV input terminals
4	PCS-CAN port	Communication port between MPPT and PCS Module
	Function port	\
	Parallel 1 port	Same as PCS-CAN port, it is in parallel together, reserved for future use.

NOTE: Refer to the separate **PCS manual** provided with this document for more detailed information.

2.6.2 PCS

The PCS converts the DC voltage discharged from the ESS into specified AC voltage and converts AC voltage into DC voltage to charge the ESS. Refer to the separate **PCS manual** provided with this document for more detailed information.

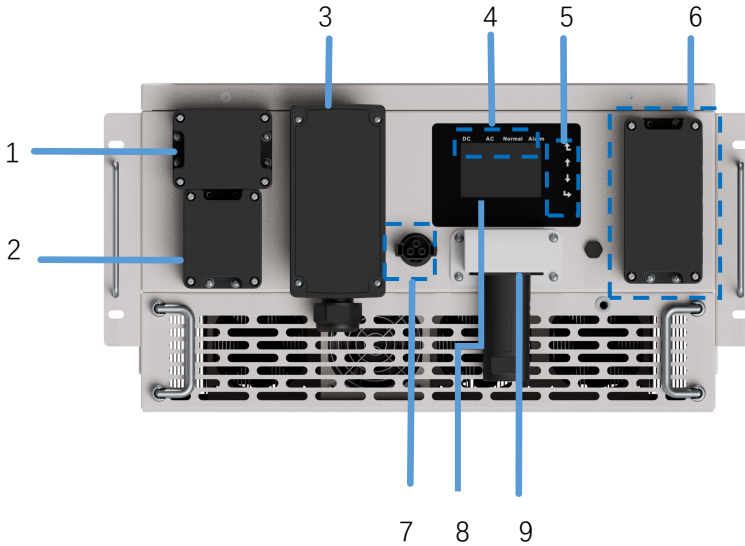

No.	Item	No.	Item
1	MPPT input	6	AC input/output port
2	Battery input	7	Auxiliary power port
3	LCD 485 port	8	LCD display
	BATBMS port		
	MPPT CAN port		
	Parallel port		
4	PCS indicators	9	Interface for logger
5	Function buttons		

2.7 Critical systems



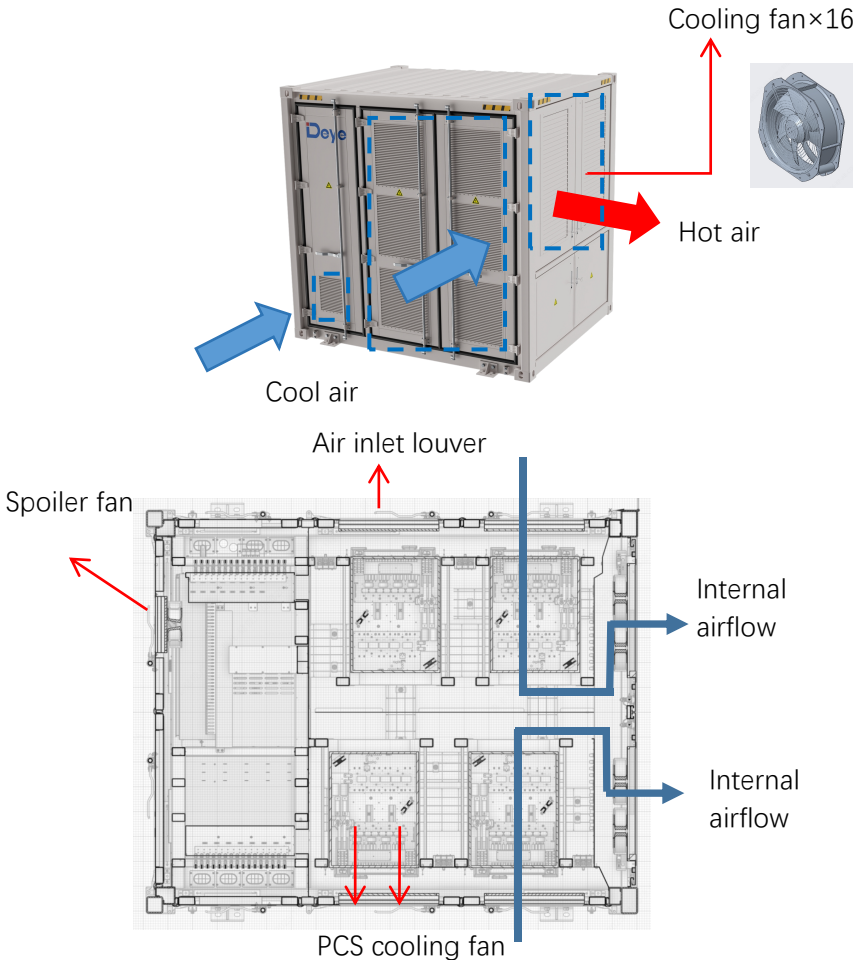

2.7.1 Thermal Management System (TMS)





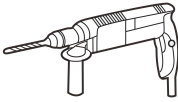

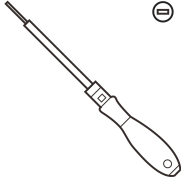
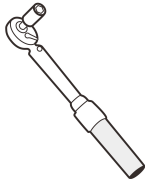
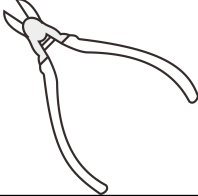
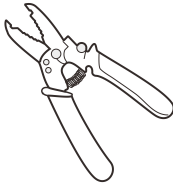
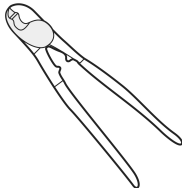
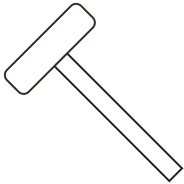
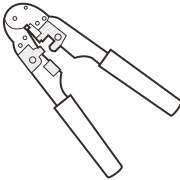
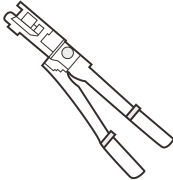
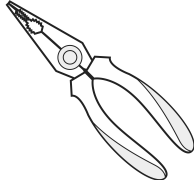

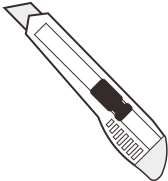
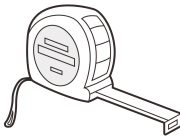
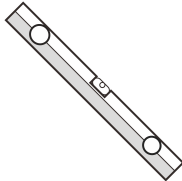
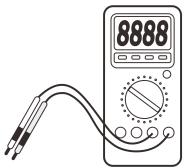

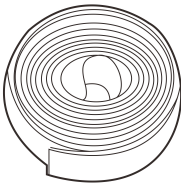
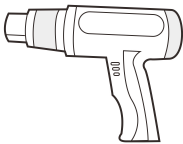
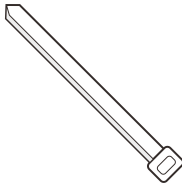

When the TH (temperature and humidity) sensor detects the temperature is higher than 50°C, the spoiler fan activates.

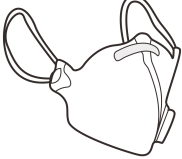

3 Installation

3.1 Materials Required

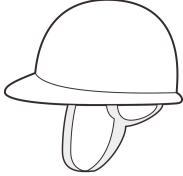
Tools			
			
Hammer drill	Phillips insulated torque screwdriver	Flat-head insulated torque screwdriver	Insulated torque socket wrench
			
Diagonal pliers	Wire stripper	Cable cutter	Rubber mallet
			
RJ45 crimping tool	Hydraulic pliers	Needle-nose pliers	Marker
			

Utility knife	Steel measuring tape	Level	Multimeter DC voltage measurement
			
Heat shrink tubing	Heat gun	Cable tie	Insulated ladder
			
Powered industrial forklift	Crane		
			
Personal Protective Equipment			
			
Insulated gloves	Protective gloves	Goggles	Dust mask
			
Insulated shoes	Safety helmet	Protective suit	

3.2 Moving Heavy Objects

After arrival of your goods, perhaps you need move it to designated working area.

When moving your product:

- Keep at least 2m away from the forklift during operation.
- No passengers are permitted to stand on or be lifted by forklifts.
- Do not overload forklifts or raise loads too high, as this can affect overall stability.
- Maintain speeds below 3mph and avoid sharp turns.
- Before reversing, the forklift operator must check behind them and ensure it is safe to proceed.
- When reversing in confined spaces, a spotter is needed, who directs the forklift operator.
- Use caution when lifting this load on uneven surfaces.
- Never operate the forklift on slopes ≥ 5 degrees.
- During movement, avoid tilting the cabinet or placing it upside down. If the cabinet must be tilted or inverted, please straighten it as soon as possible, and the cabinet needs to be left standing for 2 hours before it can be powered on.
- Suggest to insert the forklift tooth into the position indicated by the "Forklift fork insertion" in the package material.
- When lifted heavy unbalanced load, refers to the marking for center of gravity location.

3.3 Unpacking





Warning!

- After setting up the equipment well, carefully unpack the package so as to avoid scratching equipment.
- If possible, do not remove the transport packaging before arrival at the installation site.
- After unpacking, check whether the fasteners and removable parts are missing. If they are missing, please contact you vendor at once.
- Keep the equipment stable during unpacking.

- If the installation environment is not friendly to the equipment, take measures to prevent failure inside the cabinet caused by condensation or dust corrosion (for example, cover with woven cloth or dust cover).

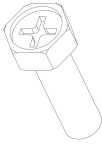
After unpacking the equipment, check that the deliverable contents are intact and complete, and free from any damage. If any items listed in the *Packing List* is missing or damaged, contact your dealer or call service hotline: **+86-0574-86320560**.

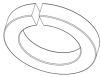
Packing List				
				
Cabinet mounting feet×4 pcs		Hex bolt	M20*55 ×20 pcs	Flat washer ×20 pcs
			M12*30 ×8 pcs	
				
Spring washer	Φ20 ×20 pcs			
	Φ12 ×8 pcs			

3.4 Hoisting

3.4.1 Hoisting Equipment



Warning!

- The hoisting personnel must be trained and qualified until they can take up the post.
- Use only approved lifting equipment to move the cabinet.



Warning!

- Never operate the lifting equipment in bad weather, such as typhoon, heavy rain, thick fog, thunder and so on.
- Before hoisting, ensure that the crane and hoisting ropes meet the load-bearing requirements.
- Do not drag the cabinet when assembling or disassembling the hoisting equipment. Otherwise, the cabinet may be scratched.
- Do not lift or move the equipment after fixing the cabinet.
- Ensure that all doors of the equipment are closed and locked before hoisting.

3.4.2 Hoisting the Product



Warning!

Remember to make sure that your device is connected to the lifting tool correctly and firmly before hoisting. Failure to do so may result in product damages, serious injury, even death.

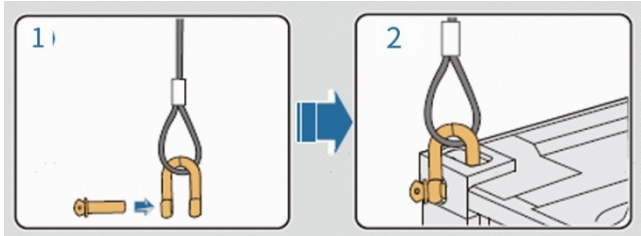

Figure.1

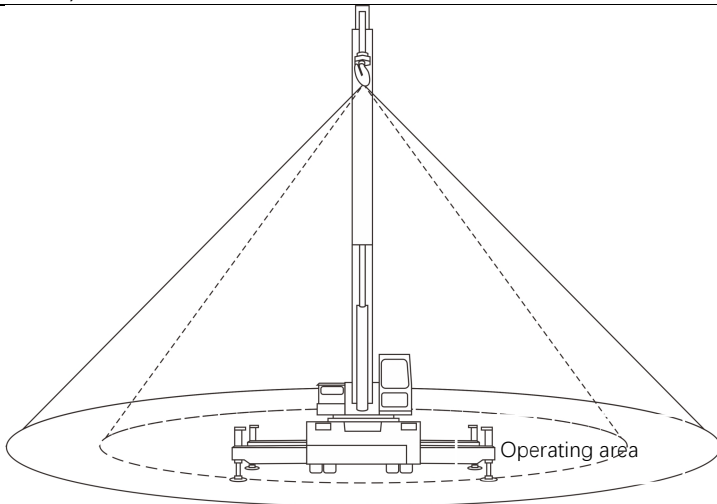

Figure.2

- Ensure that all sling connections are safe and reliable, and that the lengths of the slings connected to the corner fittings are equal. See the Figure.1.
- Do not stand within 0.5-1m of the lifting area! During the whole lifting process, no one is allowed to stand under the boom or the work station. See the Figure.2
- A professional instructor is needed in the whole hoisting process.
- The length of the sling can be adjusted appropriately according to the actual requirements of installation site.
- During the lifting process, the devices must be stable and not skewed.
- Please lift the devices from the bottom.
- It is recommended to hoist the equipment from left to right or from right to left to ensure the smooth hoisting.
- Ensure that the crane position is suitable, no long distance hoisting.
- The equipment should be hoisted vertically and should not be dragged on any surface during hoisting.
- Do not shake the crane in order to avoid sudden drop or shock against equipment.
- Hoisting should be handled gently, and the cabinet should fall slowly and smoothly to avoid shock against equipment.

3.5 Installation



Warning!

- Your product is delivered without full charge. It is recommended to make your equipment charged within three months.
- Assembly must be carried out in accordance with the design, technological requirements, regulations and relevant standards.
- The parts must be cleaned before assembly, free of burrs, flash edges, oxide, rust, sand, dust and stains.
- The parts shall not be bumped, scratched or rusted during assembly.
- Wear appropriate personal protective equipment at all times during any assembly operation on site. The following personal protective equipment is considered a minimum requirement:
 - In a dry environment, wear S3 safety shoes .
 - On rainy or wet ground, wear S5 safety boots .
 - Wear flame-retardant work clothes.
 - Wear flame-retardant work pants.
 - Safety gloves.

3.5.1 Installation Requirements

3.5.1.1 Installation Torque

Applicable for : Cabinet assembly / Sheet metal fixing / Bracket connection.

Note : ① Strictly follow the recommended torque, avoid over-tightening/under-tightening; ② Unit: N·m (Newton meters)

Bolt Specification	Recommended Torque	Unit
M3	0.7 ~ 0.9	N·m
M4	1.6 ~ 2.2	N·m
M5	3.2 ~ 4.4	N·m
M6	5.3 ~ 7.4	N·m
M8	12 ~ 19	N·m

M10	25 ~ 38	N·m
M12	44 ~ 65	N·m
M14	54 ~ 108	N·m
M16	110 ~ 165	N·m
M18	150 ~ 240	N·m
M20	216 ~ 335	N·m

Supplementary Instructions:

1. The torque value is for reference only for standard bolts during normal assembly; adjust appropriately for special working conditions (high vibration/harsh environment).
2. Use a calibrated torque wrench for installation to ensure torque accuracy.

3.5.1.2 Installation Personnel

- Only qualified professionals or trained personnel are allowed to install the equipment.
 - Professionals:personnel who are familiar with the working principles and structure of the equipment, trained or experienced in equipment operations and are clear of the sources and degree of various potential hazards in equipment installation.
 - Trained personnel:personnel who are trained in technology and safety have required experience,are aware of possible hazards on themselves in certain operations and are able to take protective measures to minimize the hazards on themselves and other people.
- Personnel who plan to install the equipment must receive all necessary safety precautions and local relevant standards.
- Only qualified professionals are allowed to remove safety facilities and inspect the equipment.
- Knowledge of electronic, electrical wiring and mechanical expertise, and be familiar with electrical and mechanical schematics.
- Understanding and complying with this document and other applicable documents.

3.5.1.3 Installation site requirements



Danger!

Do not expose the equipment to flammable or explosive gas or smoke. Do not perform any operation on the equipment in such environments.



Danger!

Do not store any flammable or explosive materials in equipment area.



Danger!

Do not place the equipment near heat sources or fire sources, such as smoke, candles, heaters, or other heating devices. Overheat may damage the equipment or cause a fire.



Warning!

Install the equipment in an area far away liquids. Do not install it under areas prone to condensation, such as under water pipe and air exhaust vent, or area prone to water leakage, such as air ventilation vents, or feeder windows of the equipment room. Ensure that no liquid enters the equipment to prevent faults or short circuits.



Warning!

To prevent damage or fire due to high temperature, ensure that the ventilation vents or heat dissipation systems are not obstructed or covered by other objects while the equipment is running.



Warning!

Do not install the equipment near areas that may produce interfering gases, such as garbage dumps or chimney outlets.

- The installation and usage environment must meet relevant international, the local laws and regulations. The user is obliged to protect the device against fire or other hazards.
- Do not install in low-lying areas. The installation level must be at least 300mm higher than the highest water level in the area.
- To protect the equipment from wildfires caused by high temperatures in summer, it should be free of vegetation and flammable plants within

3 meters of the surrounding area.

- Considering safety, the distance between the equipment and residential buildings should be more than 12m, and the distance between the equipment and schools, hospitals and other densely populated buildings should be more than 30.5m. If this safety distance cannot be met, a firewall should be built between the equipment and the building.
- The safe distance between the equipment and the production building shall comply with local fire codes or standards.
- Outdoor storage systems should be at least 10 feet away from boundaries, public roads, buildings, flammable materials, hazardous materials, high piles, and other hazards not associated with the grid infrastructure.
- The equipment should be installed in an environment free from the risk of explosion.
- During the installation, commissioning, and operation of the cabinet, comply with the principle: the number of fire extinguishers near each unit is not less than 2.
- The distance between the exhaust device of the product and the heating, ventilation, and air conditioning intakes, windows, doors, discharge platforms, and fire sources of other buildings or facilities shall be more than 4.6m.
- Reserve enough space for expansion according to the needs of the whole life cycle.
- Ensure that the equipment is installed in a clean, dry and well ventilated area with proper temperature, humidity ,altitude range and so on. Check for more data in the “ **Technical Specifications**” section.
- Do not install the device in salt-damaged or polluted areas because they may be corroded. This product can be used in the following or better environments:
 - In a place where is 2000m far away from the coast. It is not recommended to use the equipment when it within 500m to 2000m away from the coast . The equipment cannot be used when the distance from the coast is less than 500m .
 - In a place where the distance from heavy pollution sources, such as smelters, coal mines, thermal power plants, is more than 1500m at

least.

-In a place where the distance from moderate pollution sources such as chemical, rubber, and electroplating is more than 1000m at least.

-In a place where the distance from light pollution sources such as food, leather, heating boilers, slaughter houses, centralized garbage dumps, and sewage treatment stations is more than 500m at least.

- Keep the product out of the reach of children and away from daily working or living area, including but not limited to the following areas:studio, bedroom, lounge, living room, music room, kitchen,game room, room theater, sunroom,toilet,bathroom,laundry,and attic.
- Do not install the equipment in places without proper fire fighting facilities, or difficult for firefighters to access.
- Do not install the equipment in an easily accessible position because the temperature of the enclosure and heat sink is high when the device is running.
- Do not install the cabinet on a moving object, such as ship, train, or car.
- Do not install the equipment in an environment with magnetic dust, volatile or corrosive gases, infrared and other radiations, organic solvents, conductive metal,or salty air.
- Do not install the equipment in an area conducive to growth of microorganism such as fungus or mildew.
- Do not install the equipment in an area with strong vibration, noise, or electromagnetic interference.
- Do not install the equipment in an position that may be submerged in water.

3.5.1.4 Foundation requirements

An inadequately constructed foundation can introduce substantial challenges to the installation of this product, affecting the smooth operation of doors and the overall functionality of the system. Consequently, the foundation must be meticulously designed and constructed in accordance with established standards. This ensures it fulfills the necessary requirements for mechanical support, cable routing, and future maintenance and overhaul operations. During the

construction of the foundation, at least the following criteria must be satisfied:

1. **Surface Material:** Install cabinets on concrete or other non-combustible surfaces.
2. **Surface Condition:** Ensure the surface is level, secure, flat, with sufficient load-bearing capacity, and free of depressions or tilts.
3. **Concrete Specifications:** Default to C30 grade concrete with a thickness of 200mm if not specified.
4. **Extension Beyond Cabinet:** Extend each side 300mm beyond the cabinet edges.
5. **Reinforcing Steel Bars:** Use HRB400 (Grade III) steel bars, 12mm diameter, spaced 150mm apart.
6. **Anti-Corrosion Measures:** Apply anti-corrosion treatments to steel bars after rust removal as per standards.
7. **Bedding Layer:** Use a 100mm thick C15 grade bedding layer under the slab.
8. **Bearing Stratum:** Foundation bearing stratum must be undisturbed soil with a characteristic bearing capacity $\geq 100\text{Kpa}$.
9. **Dewatering Measures:** Implement dewatering during construction to prevent waterlogging in the foundation pit.
10. **Excavation Safety:** Ensure proper safety measures for excavation support.
11. **Water Prevention:** After excavation, the foundation pit must not be soaked in water. If disturbed by water, further excavation and replacement filling are required.
12. **Height Requirement:** The foundation must be higher than the local historical highest water level and at least 300mm above the ground level.
13. **Drainage System:** Build drainage facilities according to local geology and municipal drainage requirements to ensure no water accumulation occurs at the equipment foundation. It should meet the drainage needs for the largest rainfall in local history. Discharged water from the drainage system must be treated in accordance with local laws and regulations.
14. **Surface Leveling:** The levelness error between the equipment

foundation and the cabinet contact surface must be $\leq 3\text{mm}$.

15. **Pit Compaction:** The bottom of the equipment foundation pit must be compacted and leveled before proceeding with construction.

16. **Weight Bearing:** The equipment foundation is configured according to the total weight of the equipment. If the bearing capacity of the foundation does not meet requirements, re-verification is necessary.

17. **Cable Management:** When building the foundation, consider the cable outlet of the equipment and reserve trenches or inlet holes accordingly.

18. **Sealing:** Both the reserved holes of the equipment foundation and the inlet holes at the bottom of the equipment should be sealed after installation.

Cable Trench Requirements

For energy storage cabinets adopting the bottom cable entry method, a trench must be pre-installed on-site since no side cable inlets are provided to prevent foreign objects from entering. The following requirements apply to the trenches:

1. **Dust-proof and Rodent-proof Design:** To avoid foreign objects entering the energy storage cabinets, the trench must have an effective dust-proof and rodent-proof design.

2. **Waterproof and Moisture-proof Measures:** In order to prevent cable aging and short circuits that could impact the normal operation of the energy storage cabinets, the trench needs waterproof and moisture-proof measures.

3. **Sufficient Cable Bending Radius:** Considering the larger power rating of the energy storage cabinets and the requirement for thicker cables, the trench design must take into account the cross-sectional area of the cables and provide a sufficient bending radius.



Warning!

The foundation drawing cannot be used as the final construction drawing but only for reference. Users must verify the design

parameters of the foundation based on the installation environment, ground bearing capacity, geological conditions, and seismic requirements of the project site.

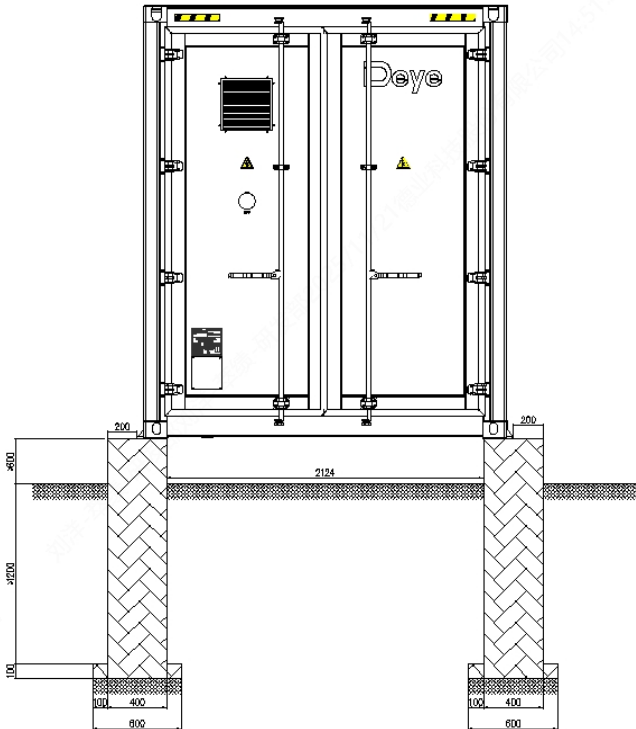

3.5.1.5 Installation clearance requirements

Single WS-PCS2250-2-A:

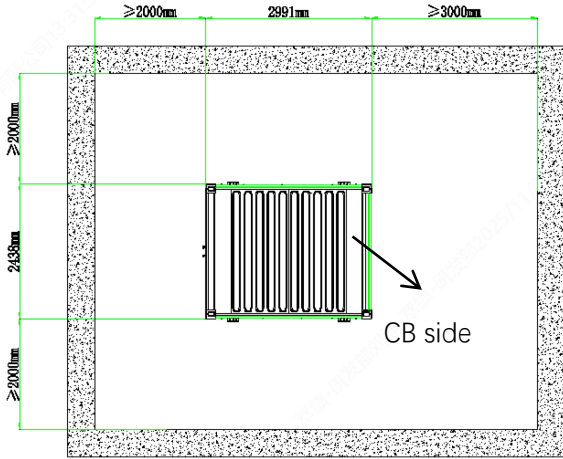

Multiples of WS-PCS2250-2-A in parallel:

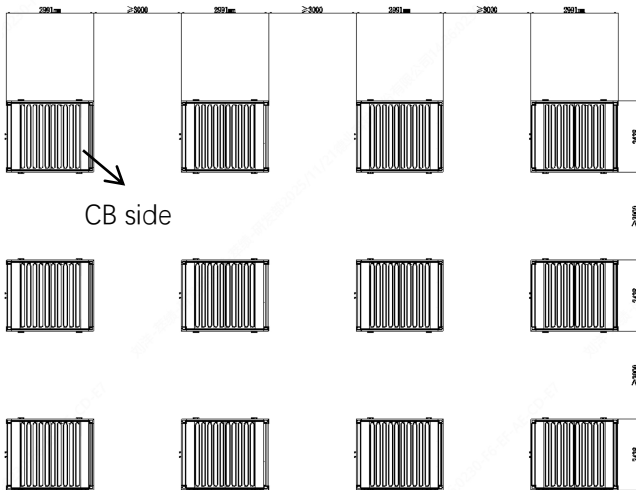

3.5.2 Fixing the Product

There are two installation methods, which differ in the step to fix the cabinet to the ground.

Method 1 :

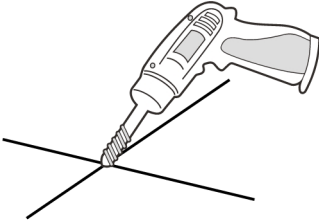

Figure.1

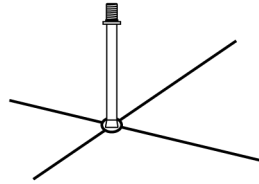

Figure.2



Figure.3



Figure.4

1. Drill holes on the ground using an electric hammer.(Figure.1)
2. Pre-install 8 expansion bolts. The recommended specification for the bolt is M20, with a torque of 260 N•m.(Figure.2)
3. Put the equipment in place and fix Cabinet mounting feet to the cabinet body using 8 M20x55 hex bolts, 8 flat washers and 8 spring washers with 260 N•m.(Figure.3)
4. Then secure the equipment to the ground by attaching their nuts onto expansion bolts.(Figure.4)

Method 2 :

1. Making sure channel steels are embedded in the foundation.
2. Put the equipment in place and fix Cabinet mounting feet to the cabinet body using 20 M20x55 hex bolts, 20 flat washers and 20 spring washers with 260 N•m.(Figure.3)
3. Then secure the equipment to the ground by fully welded to the channel steel embedded in the foundation.

4 Electrical Connection

4.1 Preparation before Connection



Notice! High voltage! Shock!

- Do not contact live parts directly without protection!
- Before installation, ensure that there is no voltage on the AC side and DC side.
- Do not place the equipment on a flammable surface.



Warning!

- Sand and moisture infiltration can damage the electrical equipment in the container or affect its operating performance!
 - Do not perform electrical connections during sandstorms or when the relative humidity of the surrounding environment is greater than 95%.
 - Make electrical connections when there is no wind or sand and when the weather is clear and dry.
- Before connecting cables, check that the polarity of all input cables is correct. Do not pull wires and cables forcibly during electrical installation. • Otherwise, the insulation performance may be affected. Make sure all cables and wires have enough room to bend. Take necessary auxiliary measures to reduce the stress on cables and wires.
- After each connection is complete, carefully check whether the connection is correct and secure.

4.1.1 Cable Requirements

When wiring, cables are supposed to meet the following requirements:

- Sufficient current-carrying capacity. Factors that can influence this capacity are shown as follows:
 - environment condition;
 - the type of insulated materials of conductors;
 - cable routing;
 - material and cross-section of cables;
- Suitable diameter and length of cables
- Correct specification and material of cables used for DC input
- Correct specification and material of cables used for AC input
- Only use fire-resistant cables.

How to crimp an OT or DT terminal?

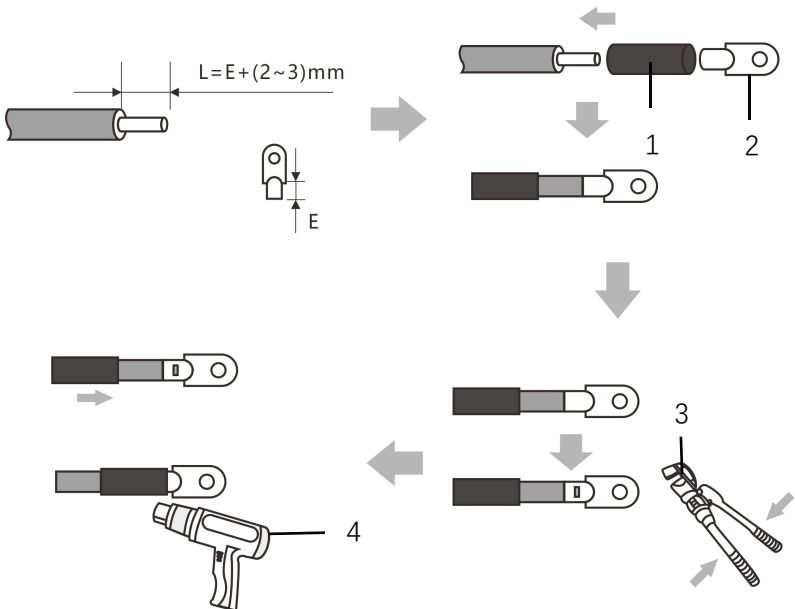

NO.	Description	NO.	Description
①	Hot air duct	③	Hydraulic pliers
②	OT/DT	④	Heat Gun

4.1.2 Opening the Door

There are two door designs, therefore two door opening methods are shown herein.

Method 1:

2



Figure.1



Figure.2



Figure.3

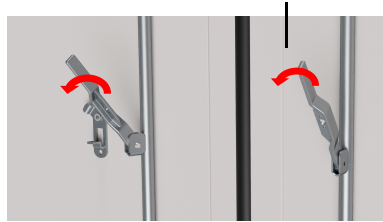

Figure.4



Figure.5

1. Use the provided key to open the **U-lock** and remove the U-lock.
2. Slide the two **bolts(A)** to unfasten the door handles. See the Figure.1

3. **Rotate** the two **door handles(B)** by **180°**. See the Figure.2 and Figure.3.
4. **Rotate** the handles **outward** and then **pull** it forcefully to open the door. See the Figure.4 and Figure.5.

Method 2:



Figure.6



Figure.7



Figure.8



Figure.9



Figure.10

1. Insert the **key** fully into the lock cylinder. **Turn** the key firmly until you hear a click, indicating the lock is unlocked. See the Figure.6 and Figure.7.
2. Grasp the key to **pull door handles** out of lock cylinder. See the Figure.8.
3. Hold the door handle(s) firmly and **rotate** them until they reach the **upright (vertical) position**. See the Figure.9.
4. Stand clear of the door's swing path. Holding the handle(s), **pull** the **door(s)** outward smoothly and fully open them. See the Figure.10.

4.2 Cable Connection



Danger!

All electrical connections must be made when the equipment is completely powered off.



Danger!

Do not smoke or have an open flame around batteries. wear personal protective equipment and use dedicated insulated tools to avoid electric shocks or short circuits.



Warning!

- Equipment damage caused by incorrect connections is not covered by the product warranty.
- Only qualified electrical technicians are allowed to connect cables.
- Operation personnel must wear proper PPE when connecting cables.



Warning!

When connecting cables, do not place installation tools, metal parts, or sundries on the device. After the connection, clean up objects around the area.



Caution!

- Do not connect two or more cables to the positive or negative power port a battery in parallel.
- Stay away from the equipment when preparing cables to prevent cable scraps from entering the equipment. Cable scraps may cause sparks and result in personal injury and equipment damage.

⚠ Caution!

When connecting to inverters or being in parallel mode, please use cables provided in the unpacking list. If other cables must be used in special cases, ensure they meet relevant standards.

4.2.1 Connection guidance

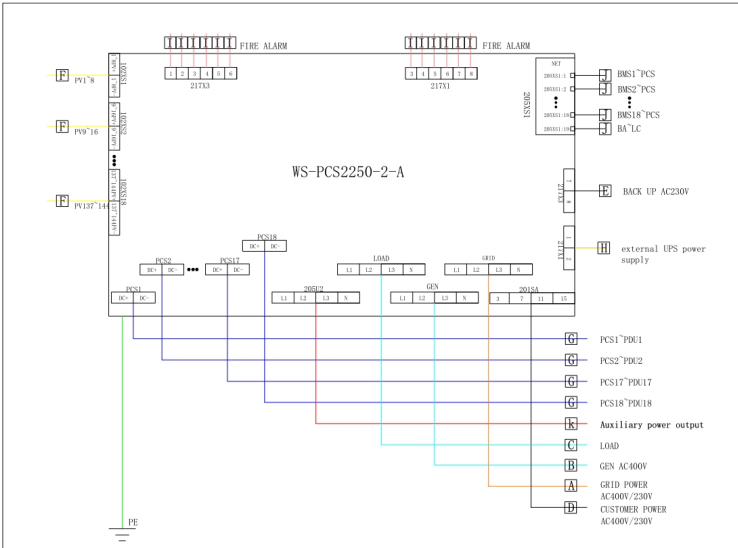

Cable	Recommended size	Torque
A	240mm ²	85 N·m
B	240mm ²	85 N·m
C	240mm ²	85 N·m
D	25mm ²	—
E	2.5mm ²	—
F	10mm ²	—

G	70mm ²	15N·m
H	2.5mm ²	——
I	0.5mm ²	——
J	CAT5E TFP	——
K	25mm ²	6.78N·m

4.2.2 Connection steps

How to position terminals related?

1. Auxiliary power and external power supply

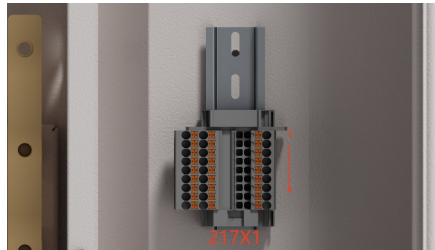
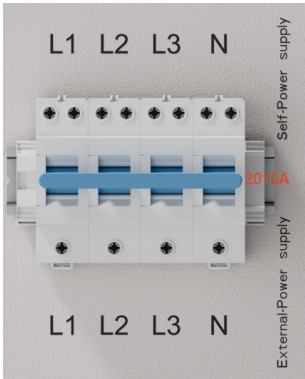

Item	Port	
Aux. power	201SA	1/5/9/13
	217X1	1/2
External power	205U2	
	217X3	7/8

2. Communication cable



Cable	Port
Communication cable	205XS1:1~21

3. Fire alarm signal

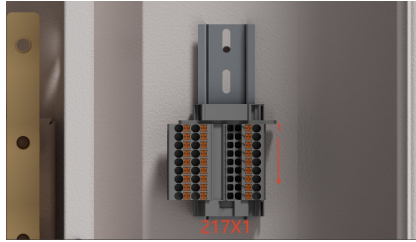

Cable	Port
Signal connection	217X1:3~8
	217X3:1~6

4. AC Power cable

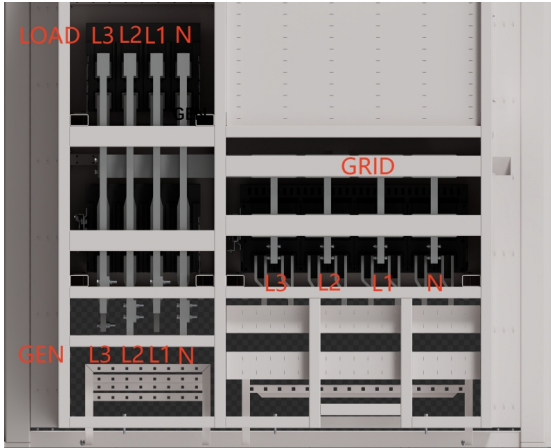

Cable	Port	
AC power cable	GRID	L1
		L2
		L3
		N
	GEN	L1
		L2
		L3
		N
	LOAD	L1
		L2
		L3
		N

5. DC Power cable



Cable	Port
DC power cable	P1+~P18+
	P1-~P18-

6. PV cable

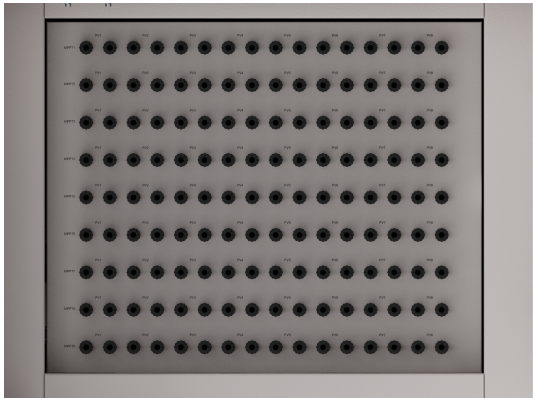

Cable	Port
PV cable	PV1+~P144+
	P1-~P144-

7. Ground cable



Type	Bolt	Cable section	Torque (N • m)
Protective earth	M12x30 (8 pcs)	50×5mm ²	55

5 Operation Instructions

5.1 Powering on the Equipment

5.1.1 Check Before Power-On

General Check

No.	Check Item	Acceptance Criteria
1	Appearance	<ul style="list-style-type: none">• The equipment is intact and free from rust or paint flake-off. If the paint flakes off, repair the damaged paint.• The labels on the device are clear. Damaged labels must be replaced.
2	Cable appearance	<ul style="list-style-type: none">• Cable sheathings are properly wrapped and not damaged.• Cable hoses are intact.
3	Cable connection	<ul style="list-style-type: none">• Cables are connected in the designed positions.• Terminals are prepared as required and securely connected.• Labels on both ends of each cable are clear and specific, and attached in the same direction.
4	Cable routing	<ul style="list-style-type: none">• Cables are neat and tidy.• Cable tie joints are evenly cut without burrs.• Cables are placed properly and with slack at bending points to avoid stress.• Cables are routed neatly without twists or crossovers in the cabinets.

Cabinet

No.	Check Item	Acceptance Criteria
1	Installation	<ul style="list-style-type: none"> The installation meets the design requirements. The cabinet is level, and each door opens normally.
2	Appearance	<ul style="list-style-type: none"> The cabinet surface is free from cracks, dents, and scratches. If the paint flakes off, repair the damaged paint.
3	Cabinet grounding	<ul style="list-style-type: none"> Ground the cabinet correctly according to the requirements of the power distribution system.
4	Accessory	<ul style="list-style-type: none"> The number and positions of accessories installed meet design requirements.
5	Label	<ul style="list-style-type: none"> All labels are correct, clear, and complete.

Interior

No.	Check Item	Acceptance Criteria
1	Cable	The bolts for installing the cables are tightened and the cables are not loose.
2	Cable hole sealing	Cable holes are sealed.
3	Components	All components are intact.
4	Foreign object	Foreign objects such as tools and remaining materials are cleared.
5	Meter	The meter is free from cracks, dents, and damage, and its buttons are normal.
6	Cabinet grounding	The ground conductor is securely connected to the ground terminal of the cabinet.

5.1.2 Power-On Operations



Danger!

Wear insulated gloves and use insulated tools to prevent electric shocks or short circuits.



Caution!

- During the power-on procedure, monitor the system for faults. If you detect any faults, power off the ESS, rectify the faults, and then continue with the procedure.
- If batteries are fully discharged or over-discharged during system installation and commissioning, charge the batteries promptly to prevent damage due to over-discharge.
- If the ESS has not been used for six months or longer after being installed, it must be checked and tested by professionals before operation. If a circuit breaker in the ESS trips, check the corresponding load side.
- Turn on the circuit breaker only after you have confirmed that there is no short circuit or other fault to prevent the fault from spreading and causing safety risks.



Notice!

Before power-on and long-term operation, remove the desiccants from the ESS and dispose of them according to the applicable local waste disposal act. If the ESS is powered off immediately after being powered on, keep the desiccants in the ESS.

Since PCS containers and battery containers are typically used in combination, the WS-L4300-BC-2-A3 container and WS-PCS2250-2-A container are taken as examples to illustrate the specific steps.

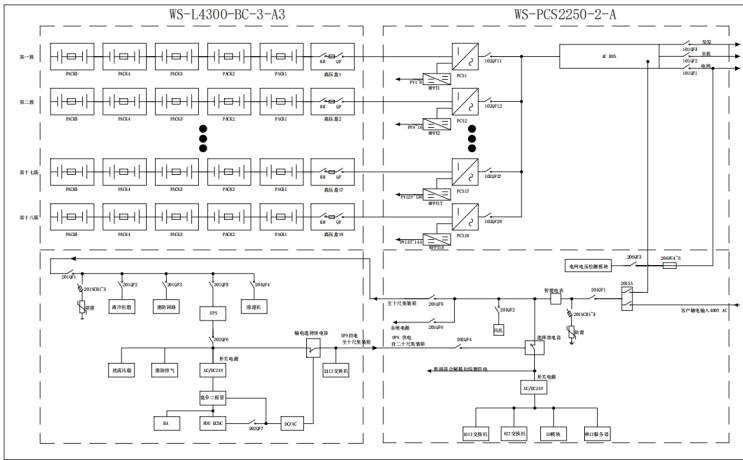

1. Press the SATRT button on the DC PDU, close the circuit breaker QF on the DC PDU, and close the 202QF7 in the WS-L4300-BC-2-A3 container.

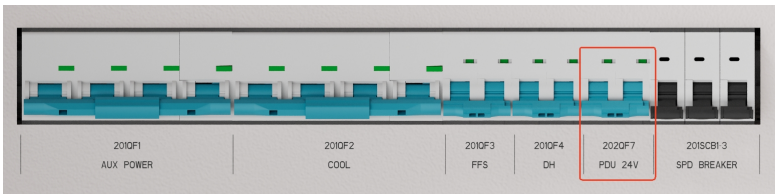
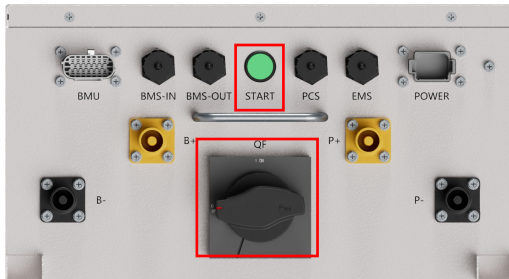

2. Close circuit breakers 202QF4 and 206QF3 and 101QF1 (long press the START button on the operation panel for 2 seconds) in the WS-PCS2250-2-A container.

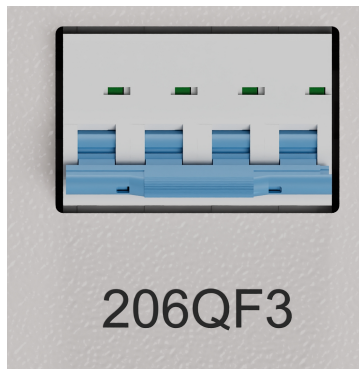
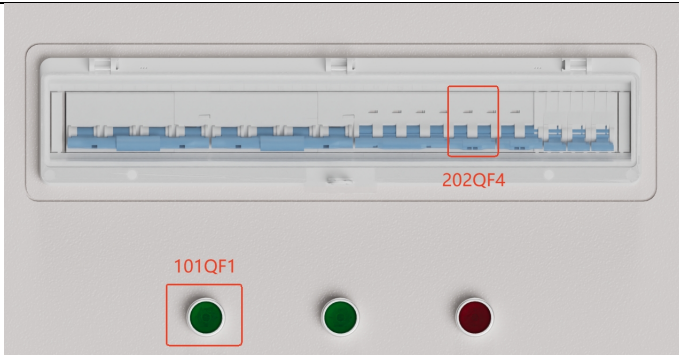

3. Close 201SA, 201QF1, 201QF2, and 201QF5 in sequence in the WS-PCS2250-2-A container.

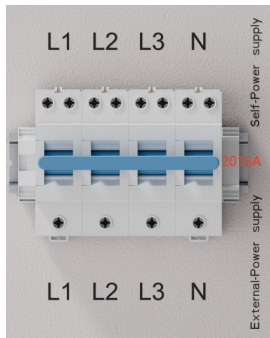

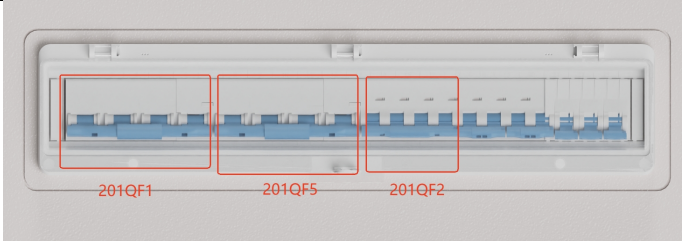

4. Close 201QF1, 201QF2, 201QF3, 201QF4, 202QF5 and 202QF6 in sequence, and press the start button of the UPS for 2 seconds in the WS-L4300-BC-2-A3 container.

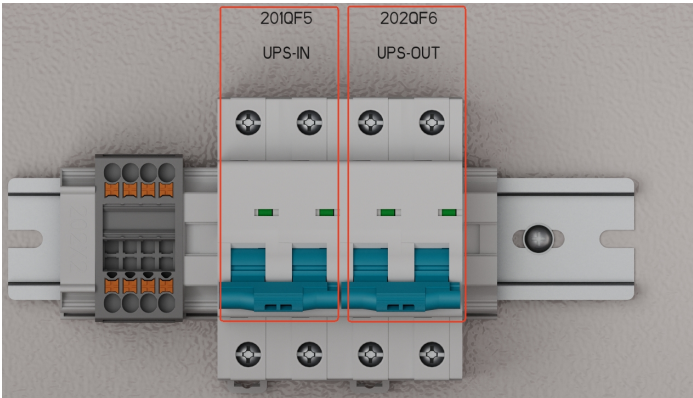
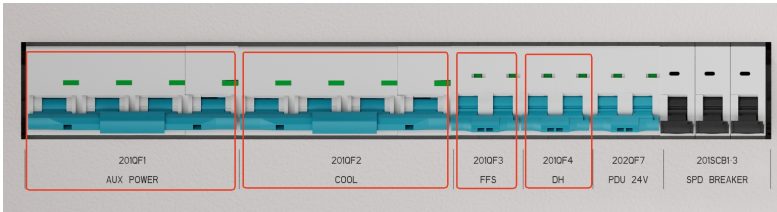

5. Close the 18 PCS AC-side switches in sequence in the WS-PCS2250-2-A container.

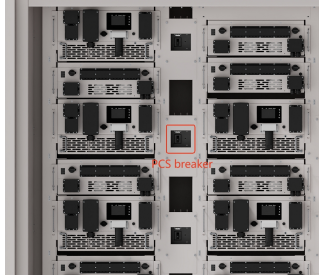

6. Power-On procedure is complete.

5.2 Powering Off The Equipment



Notice !

Press the emergency stop (EPO) to stop the ESS only in emergency situations.

1. Make sure the entire system is in halt state, in which WEB interface shows system shutdown and PCS indicators are off.



2. Disconnect the DC main relay inside the DC PDU through BMS control, manually disconnect the circuit breaker QF, and press the button on the DC PDU in the WS-L4300-BC-2-A3 container.

3. Disconnect PCS AC-side circuit breakers and then press the circuit breaker 101QF1 in the WS-PCS2250-2-A container.

4. Disconnect the 201QF6, 201QF2, 202QF4, 206QF3, 201QF5, 201QF1, and 201SA in the WS-PCS2250-2-A container.

5. Disconnect the 202QF7, 202QF6, 202QF5, 201QF4, 201QF3, 201QF2, and 201QF1 in the WS-L4300-BC-2-A3 container.

6. Press the start button of the UPS for 3 seconds and then click the "Confirm" shown on the screen later to shut down the UPS.



7. Power-Off procedure is complete.

6 Maintenance

6.1 General Maintenance



Danger!

- Servicing should be performed or supervised by professional personnel.
- Wear personal protective equipment and use dedicated insulated tools to avoid electric shocks or short circuits
- Do not smoke or have an open flame around batteries.
- Do not use wet cloth to clean exposed copper bars or other conductive parts.
- Do not use water or any solvent to clean batteries.
- Charge your equipment in 48 hours after over-discharge.



Warning!

- Do not maintain batteries with power on. Before moving or reconnecting the equipment, disconnect the mains and batteries and wait for five minutes until the equipment powers off. Before maintaining the equipment, check that no hazardous voltages remain in the components to be maintained by using a multi-meters.
- Do not wear jewelry, watches and other metal jewelry when servicing.



Caution!

- Place a warning sign indicating that switch must not be turned on at the position where the switch resides.
- Use a electroscope of a proper voltage level to check whether the equipment is energized and ensure that the equipment is completely powered off.
- Before performing maintenance or repair, securely connect the loop to be repaired to the main ground loop using a ground cable.
- After the maintenance or repair is complete, remove the ground cable between the loop that has been maintained and the main ground loop.
- Stay away from the equipment when preparing cables to prevent cable scraps from entering the equipment. Cable scraps may cause sparks and

result in personal injury and equipment damage.

- Cables should be inserted and removed in accordance with regulations. Violent or brute force operations are prohibited.
- After the maintenance is complete, clean the tools and materials in time, and check whether metal objects remain inside or on the top of the product.
- When replacing batteries, replace with the same type of spare parts.
- Do not open or damage batteries. Released electrolyte is harmful to the skin and eyes. It may be toxic.
- If you have any questions about the operation and maintenance of this product, please contact the customer service center. Do not operate without authorization.

6.2 Maintenance Schedule

6.2.1 Routine Maintenance

Maintenance Category	Maintenance Action	Expected Result
System	Log in to the system management platform (WEB/EMS/APP, etc.) to view system alarm information	● NO primary or secondary alarm info.
Indicator	Check that indicators are in normal state.	● Indicators can work normally to show the system's state
Outside the cabinet	Check that there are any foreign objects wrapped around the cabinet	● The cabinet is never wrapped around or covered by any foreign objects.

<p>Inside the cabinet</p>	<p>Perform an inspection:</p> <ul style="list-style-type: none"> ● Temperature ● Humidity 	<ul style="list-style-type: none"> ● Check that the temperature and humidity inside the cabinet are in reasonable ranges.
---------------------------	---	--

6.2.2 Quarterly Maintenance

Maintenance Category	Maintenance Action	Expected Result
<p>Safety inspection</p>	<p>Check that EPO and switches to shut off the equipment can work normally</p>	<ul style="list-style-type: none"> ● EPO and switches can work normally
<p>Cabinet</p>	<p>Perform the visual inspection:</p> <ul style="list-style-type: none"> ● Appearance ● Rust condition ● Door lock ● Vent ● Fasteners ● Settings 	<ul style="list-style-type: none"> ● There is no obvious paint peeling or rust. ● The door locks are not damaged. ● There is no dust at the vents. ● There are no insects, rodents, snakes or other animals. ● All fasteners are secured firmly. ● All technical settings can support the normal run of the equipment.

PCS	Perform an inspection: ● System operation status	<ul style="list-style-type: none">● Perform cleaning of the fans and heat sinks to maintain optimal thermal management and avoid system overheating● Ensure that all input and output parameters, including voltage, current, and power, remain within specified limits.
-----	---	---

6.2.3 Semi-annual Maintenance

Maintenance Category	Maintenance Action	Expected Result
Outside the cabinet	Perform the visual inspection: ● Inflammable materials.	There is no any inflammable objects around the cabinet.
Cabinet	Perform the visual inspection: ● Appearance ● Rust condition ● Door lock ● Vent ● Fasteners ● Settings	● There is no obvious paint peeling or rust. ● The door locks are not damaged. ● There is no dust at the vents. ● There are no insects, rodents, snakes or other animals. ● All fasteners are secured firmly. ● All parameter settings can support the normal run of the equipment.
Cables	● Check whether cables are securely connected. ● Check whether cables are damaged, especially whether the cable sheath that contacts a metal surface is damaged. ● Check whether water is entering into the cabinet	● Cables are securely connected. ● No damages are found on the cables. ● No water enters the equipment and contacts with cables. ● There are no insulating tape is peeling off. ● Cable routing is

	<ul style="list-style-type: none"> ● Check whether any insulating tape on terminals is not detached. ● Check whether all cables are routed correctly. 	<p>performed correctly and reasonably</p>
<p>PCS</p>	<p>Perform an inspection:</p> <ul style="list-style-type: none"> ● Electrical connections ● Cooling system ● Operating parameters ● Protective functions ● Operation status 	<ul style="list-style-type: none"> ● Thoroughly examine all terminal blocks for looseness, corrosion, or abnormal heating, ensuring all electrical connections are tight and reliable. ● Perform routine cleaning of fans and heat sinks to maintain effective thermal dissipation and avoid system overheating. ● Validate key operational parameters such as input/output voltage, current, and power to ensure they remain within specified limits. ● Test and confirm the functionality of critical protection mechanisms against overload, over-voltage, and over-temperature conditions. ● Assess the PCS' status to ensure it is free from fault alarms and operates stably under all conditions.

<p>Protective components</p>	<p>Perform an inspection:</p> <ul style="list-style-type: none">● Smoke detector and heat detector● Water detector● SPD <p>Perform an zeroing:</p> <ul style="list-style-type: none">● Gas detector	<ul style="list-style-type: none">● Confirm the operational status of smoke and heat detectors, as well as the ability of the ventilation fan to start correctly.● Conduct a drip test to ensure the water sensor alarms appropriately.● Validate the integrity and functionality of surge protection devices and fuses● Ensure that the gas detector has no zero drift.
------------------------------	---	---

6.2.4 Annual Maintenance

Maintenance Category	Maintenance Action	Expected Result
Outside the cabinet	Perform the visual inspection: ● Inflammable materials.	There is no any inflammable objects around the cabinet.
Cabinet	Perform the visual inspection: ● Appearance ● Rust condition ● Door lock ● Vent ● Fasteners ● Settings	● There is no obvious paint peeling or rust. ● The door locks are not damaged. ● There is no dust at the vents. ● There are no insects, rodents, snakes or other animals. ● All fasteners are secured firmly. ● All technical settings can support the normal run of the equipment.
Cables	● Check whether cables are securely connected. ● Check whether cables are damaged, especially whether the cable sheath that contacts a metal surface is damaged. ● Check whether water is entering into the cabinet ● Check whether any	● Cables are securely connected. ● No damages are found on the cables. ● No water enters the equipment and contacts with cables. ● There are no insulating tape is peeling off. ● Cable routing is performed correctly and reasonably

	<p>insulating tape on terminals is not detached.</p> <ul style="list-style-type: none"> ● Check whether all cables are routed correctly. 	
<p>PCS</p>	<p>Perform an inspection:</p> <ul style="list-style-type: none"> ● Electrical connections ● Cooling system ● Operating parameters ● Protective functions ● Operation status 	<ul style="list-style-type: none"> ● Thoroughly examine all terminal blocks for looseness, corrosion, or abnormal heating, ensuring all electrical connections are tight and reliable. ● Perform routine cleaning of fans and heat sinks to maintain effective thermal dissipation and avoid system overheating. ● Validate key operational parameters such as input/output voltage, current, and power to ensure they remain within specified limits. ● Test and confirm the functionality of critical protection mechanisms against overload, over-voltage, and over-temperature conditions. ● Assess the PCS' status to ensure it is free from fault alarms and

		<p>operates stably under all conditions.</p>
<p>Protective components</p>	<p>Perform an inspection:</p> <ul style="list-style-type: none">● Smoke detector and heat detector● Water detector● SPD <p>Perform a calibration and test the device's functions as well as the interlocking system (A gas calibration tool is required, which is not included in the energy storage cabinet):</p> <ul style="list-style-type: none">● Gas detector	<ul style="list-style-type: none">● Confirm the operational status of smoke and heat detectors, as well as the ability of the ventilation fan to start correctly.● Conduct a drip test to ensure the water sensor alarms appropriately.● Validate the integrity and functionality of surge protection devices and fuses● Ensure that the gas detector is functioning properly.

Alert labels	<ul style="list-style-type: none">● Check the warning labels.	<ul style="list-style-type: none">● All warning labels are visible, and no damages or stains on them.
Fire-resistant mud/Foundation	Perform an inspection: <ul style="list-style-type: none">● Fire-resistant mud● Foundation	<ul style="list-style-type: none">● The fire-resistant mud exhibits excellent adhesion.● The foundation is intact with a smooth surface

7 Troubleshooting

When any error exists in your equipment, please contact the service center or service engineers for help.

8 Repair Paint Damage

8.1 Prerequisites

- Do not apply paint in bad weather, such as rain, snow, strong wind, and sandstorm, when there is no shelter outdoors.
- You have prepared the required paint that matches the color palette delivered with equipment.

8.2 Paint Repair Description

The equipment appearance should be intact. If paint has flaked off, repair paint damage immediately.



Note!

Check the paint damage on the equipment and prepare appropriate tools and materials. The number of materials depends on site requirements.

8.2.1 Paint repair description

Paint Damage	Tool and Material	Procedure	Description
<p>Slight scratch (steel base material not exposed)</p> <p>Smudges and rust that cannot be removed</p>	<p>Spray paint or paint, brush (required for repainting a small area), fine sandpaper, anhydrous alcohol, cotton cloth, and paint spray gun (required for repainting a large area)</p>	<p>Steps 1, 2, 4, and 5</p>	<p>1. For a few scratches, smudges, or rust, manual paint spraying or brushing is recommended.</p> <p>2. For many scratches or large-area smudges and rusts, use a paint spray gun.</p>
<p>Deep scratch (primer damaged, steel base material exposed)</p>	<p>Spray paint or paint, zinc-rich primer, brush (required for repainting a small area), fine sandpaper, anhydrous alcohol, cotton cloth, paint spray gun (required for repainting a large area)</p>	<p>Steps 1, 2, 3, 4, and 5</p>	<p>3. The paint coating should be thin and even. Paint drops are prohibited on the coating. The surface should be smooth.</p> <p>4. Leave the repainted area for approximately</p>
<p>Logo and pattern damage</p>	<p>If a logo or pattern is damaged, provide the logo size and color number. Seek help from a local supplier of advertisement coatings to formulate a repair solution based on the logo size,</p>	<p>30 minutes before performing any further operation.</p>	

	color, and damage.	
Dent	<p>If a dent is less than or equal to 100 mm² in area and less than 3 mm in depth, fill the dent with Poly-Putty base and then perform the same operations as those for processing deep scratches.</p> <p>If a dent is greater than 100 mm² in area or greater than 3 mm in depth, ask the local supplier for an appropriate repainting solution.</p>	

8.2.2 Procedure

1. Gently polish damaged areas using fine sandpaper to remove smudges or rust.

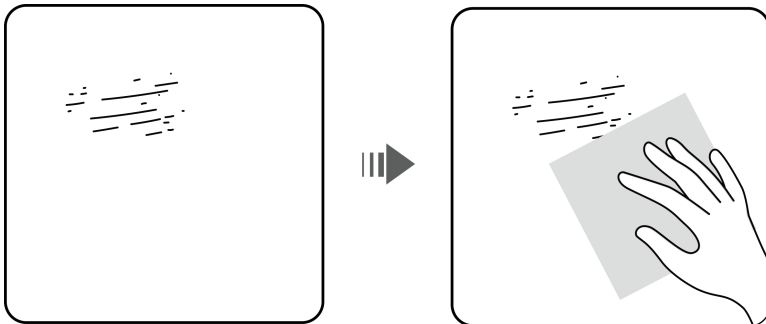

2. Dip a piece of cotton cloth into anhydrous alcohol and wipe the polished or damaged area to remove the dirt and dust. Then wipe off the anhydrous alcohol with a clean and dry cotton cloth.

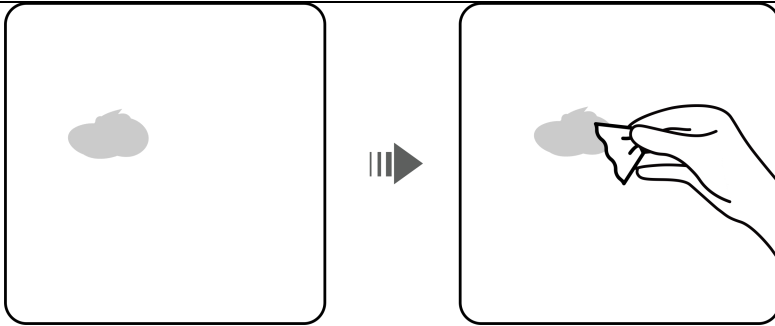

3. Paint zinc-rich primer on the damaged coat using a brush or paint spray gun.

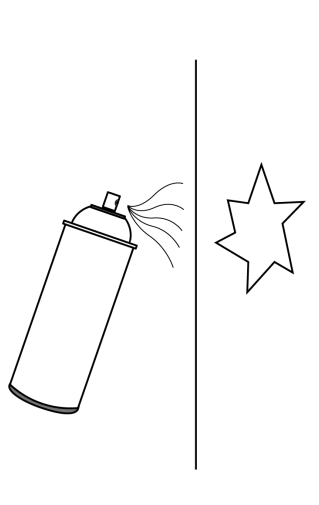

Notice!

- If the base material is exposed in the area to be repaired, apply epoxy zinc-rich primer, wait until the paint has dried, and then apply acrylic acid top coat.
- Select epoxy zinc-rich primer or acrylic acid top coat with a color the same as the surface coating color of the equipment.

4. Apply paint evenly to the damaged area based on the damage degree of the paint using an aerosol spray, brush, or paint spray gun until all damage traces are invisible.



Notice!

- Ensure that the painting is thin, even, and smooth.
- In the case that an equipment pattern has different colors, to prevent undamaged areas and those with different colors as the damaged area from being contaminated during repainting, cover such areas using white paper and adhesive tape before repairing paint.

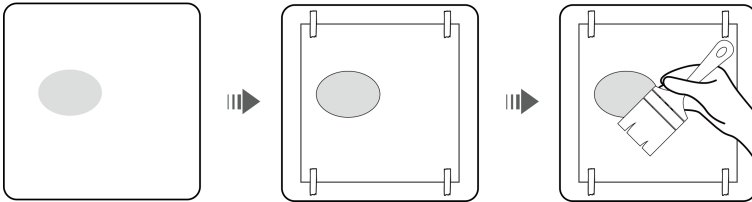

5. Wait for 30 minutes and check whether the painting meets the requirements.



Note!

- The color of the repainted area must be consistent with that of the surrounding area. Make sure that there is no visible edge between the repainted area and the surrounding area. The paint should be free of bulges, scratches, flaking, or cracks.
- If you choose to spray paint, it is recommended that you spray paint three times before checking the result. If the color does not meet the requirements, paint more times until the painting meets the requirements.

9 Emergency Handling

If an accident (including but not limited to the following) occurs on the site, ensure the safety of onsite personnel first and contact the service engineers.

9.1 Strong Impact

- If the equipment has obvious damage or abnormal odor, smoke, or fire occurs, evacuate the personnel immediately, call emergency services, and contact the professionals. The professionals shall use fire extinguishing facilities to extinguish the fire under safety protection.

9.2 Flood

- Power off the system if it is safe to do so.
- If any part of the batteries is submerged in water, do not touch the batteries to avoid electric shock.
- Do not use devices that have been soaked in water. Contact a recycling company for disposal.

9.3 Fire

Suggestions for onsite O&M personnel:

- When a fire occurs, evacuate from the building or equipment area, press the fire alarm bell, and immediately call the fire emergency service. Notify the professional firefighters and provide them with relevant product information, including but not limited to product types, capacity, and so on.
- Do not enter the affected building or equipment area under any circumstances, and do not open the doors of the equipment. Isolate and monitor the site. Keep irrelevant personnel away from the site.
- After calling the fire emergency service, remotely power off the system while ensuring your own safety.

-
- After professional firefighters arrive, provide relevant product information, including but not limited to product types, capacity, user manuals and so on.
 - After the fire is extinguished, the site must be handled by professionals in accordance with local laws and regulations. Do not open the doors of the equipment without permission.
 - Post-disaster product maintenance: Contact the service engineers for evaluation.



Suggestions for professional firefighters:



- For product information, see the information provided by O&M personnel, including but not limited to product types, capacity, user manuals and so on.
- Do not open the doors of the equipment before it is deemed safe by professionals.
- Follow local fire fighting regulations.
- When a fire occurs, prevent the fire from spreading to nearby the equipment.

10 Storage

Note!

- Only trained and qualified personnel are allowed to operate the equipment. Wear insulated gloves and use dedicated insulated tools during the operation.
- The storage environment must comply with local regulations and standards.
- You are advised to store the equipment in a dry, clean, and ventilated indoor environment that is free from sources of strong infrared or other radiations, organic solvents, corrosive gases, and conductive metal dust. Keep the equipment far away from sources of heat and fire.
- Store the equipment separately to avoid mixing with other equipment. The site must be equipped with qualified fire fighting facilities, such as fire sand and fire extinguishers.
- The equipment must be disconnected from external equipment during storage, and the equipment indicators must be off.
- Place the equipment correctly according to the signs on the packing case during storage. Do not place the equipment upside down, lay it on one side, or tilt it. The packaging signs are described as follows.

Name	Symbol	Description
Up		The package shall be kept upright during transportation and storage.
Fragile		The package contains fragile objects and shall be handled with care.
Keep dry		The package shall be protected against rain, and rainproof measures shall be taken during transportation and storage.

Do not roll		The package shall not be rolled during transportation.
Do not stack		The package shall not be stacked.

- Do not unpack the equipment if it will be stored for a long time.
- Do not stack the equipment.
- Ensure that the ground surface is flat (for long-term or temporary storage).
- Refer to the section “Technical Specification” for storage temperature and humidity.
- Close the cabinet door.
- For long-term storage (more than six months after delivery), replace the desiccants with those of the same specifications and amount.
- If the equipment has been stored for longer than allowed, promptly report the condition to the person in charge.
- Handle the equipment with care to prevent damage.

10.1 PCS Storage

When devices are stored as spare parts and will not be put into use immediately, the following storage requirements must be met:

- If devices are unpacked but will not be used immediately, put them back to the original packaging with the desiccant, and seal with tape.
- When temporarily storing devices outdoors, do not stack them on a pallet. Take rainproof measures such as using tarpaulins to protect devices from rain and water.
- Refer to the Technical specification for more information including storage temperature and relative humidity
- Do not remove the packaging. Check the packaging regularly (recommended: once every three months). Replace any packaging that is damaged during storage.
- Do not store devices for more than two years. If devices have been stored for two years or longer, they must be checked and tested by professionals before being put into use.
- To avoid personal injury or device damage, exercise caution when stacking devices to prevent them from falling over.

11 Transport

1. The products should be transported after packaging and during the transportation process. Severe vibration, impact, or extrusion should be prevented to prevent sun and rain. It can be transported using vehicles such as cars, trains, and ships.
2. Make sure all the cabinet doors are locked.
3. If your container needs to be transported on a slope, additional traction may be required.
4. Remove all existing or potential obstacles along the path, such as tree branches, cables, etc.
5. Containers must be kept upright during transport.
6. Place the equipment horizontally during transport. Ensure the inclination angle does not exceed 15 degrees throughout the entire transportation process.
7. Always check all applicable local, national, and international regulations before transportation.
8. Transportation and storage service providers must have the certification for dangerous goods operations required by local laws, regulations, and standards.
9. Before transportation, make a compliant and accurate declaration. Ensure that the packaging, labels, and markings are intact and there is no abnormal smell, leakage, smoke, or fire. Otherwise, the product must not be transported.
10. Exercise caution when moving batteries to prevent bumping and ensure personal safety.
11. Unless otherwise specified, dangerous goods must not be mixed with goods containing food, medicine, animal feed, or their additives in the same vehicle or container, and sharp objects are not allowed in the same vehicle or container.
12. Store batteries in a separate area away from heat sources. Protect batteries from moisture, water, and rain. Stack batteries according to the labels on the packing case. Do not stack batteries more than the allowed stacking layers. Do not place batteries on one side or upside down.
13. When transporting faulty batteries, avoid approaching flammable

material storage areas, residential areas, or other densely populated places, such as mass transit facilities or elevators.

- Transport service providers must be qualified for the transport of dangerous goods.
- Comply with the international rules for the transport of dangerous goods, and meet the regulatory requirements of the transport regulatory authorities of the country of origin, route and destination.
- The transportation should be by sea or road with good road condition, not by rail or air. Turbulence and tilt should be minimized during transportation.
- Shipping complies with the shipping requirements of the International Maritime Dangerous Goods Code (IMDG Code).
- Land transport complies with ADR or JT/T 617 transport requirements.
- The shipping cases must be secure, handled with care and protected from moisture during loading, unloading and transportation.
- Handle batteries with care. Do not touch them and pay attention to personal safety.
- Unless otherwise specified, dangerous goods cannot be mixed in the same vehicle or container with goods containing food, pharmaceuticals, animal feed and their additives.

Shipping:

1. The external gaps of containers must be sealed with sealing plates and bags before shipment to ensure that internal devices are not affected during transportation
2. For protective shell. Avoid bumps during transportation, prevent paint film scratches, equipped with rainproof canvas cover.
3. When shipping by sea, it is necessary to attach relevant marks certified by classification society: owner code, case number, weight and other relevant marks.
4. When shipping by sea, it is necessary to obtain MSDS certification and paste the label of Category 9 dangerous goods.

Land Transportation:

1. Obey traffic rules.
2. The container equipment has been loaded with batteries, it is

prohibited to speed on flat asphalt roads, the speed limit is 70 km/h on highways, and the speed limit is 50 km/h when turning; Town road 40 km/h, avoid emergency start and emergency braking.

3. For land transportation, vehicles equipped with twist locks are recommended. If twist locks are unavailable, secure the product using lashing straps. The product must be lashed at both the top and bottom to the transport vehicle to prevent excessive tilt angles during transit, thereby avoiding product shifting and overturning.

12 Technical Specifications

Model	WS-PCS2250-2-A
PCS Data	
AC Rated Power	2250kW (18×125kW)
AC Rated Voltage / Frequency	400Vac / 50Hz (3L+N+PE)
AC Rated Current	3248A (18×180.4A)
Max Power	2250kW (18×125kW)
Power Factor	-1 ~ +1
Battery Input Voltage Range	648Vdc ~ 876Vdc
Max. DC Charging / Discharging Current	(18×190A)
MPPT Data	
Max. PV Input Power	2880kW (18×160kW)
Max. PV Input Voltage	800Vdc
Start-up Voltage	200Vdc
Max Operating PV Input Current	18×(40+40+40+40+40+40+40+40) A
No. of MPP Trackers	144(18× 8)
System Data	
Grid Side Data	
AC Rated Voltage / Frequency	400Vac / 50Hz (3P4W)
AC Max Current	5400A
Gen Side Data	
AC Rated Voltage / Frequency	400Vac / 50Hz (3P4W)
AC Max Current	3600A
Load Side Data	
AC Rated Voltage / Frequency	400Vac / 50Hz (3P4W)
AC Max Current	3247A
General Data	

Operating Temperature	-30°C ~ +55°C
Humidity	0 ~ 95%
Ingress Protection	IP55
Anticorrosion grade	C4-M (Optional C5)
Altitude	≤2000m
Weight	12000kg
Dimensions (W × D × H)	2991×2438×2896mm

Service Hotline: +86-0574-86320560

Email: service-ess@deye.com.cn

Website: <http://deyeess.com>

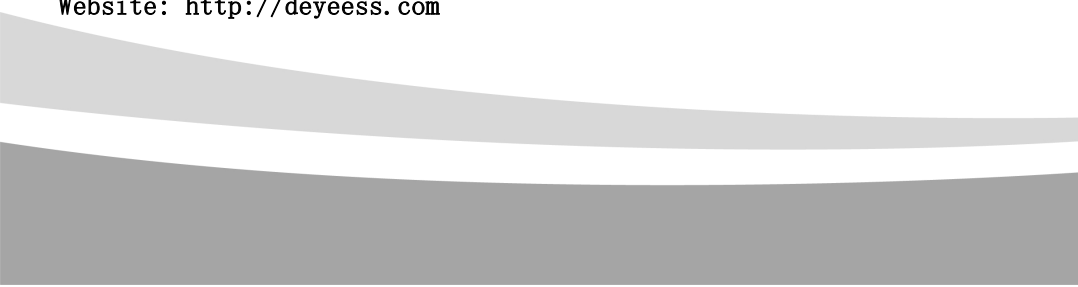
The bottom of the page features a decorative graphic consisting of three overlapping, wavy horizontal bands. The top band is a light gray color, the middle band is white, and the bottom band is a darker gray color. These bands curve across the width of the page, creating a modern, abstract footer design.